

VERSATILE 10 SEC INSTANT VOICE ROM

JUNE 1999

FEATURES

- * Minimum 10 second voice length at 6 KHz
- * Versatile features for playback
- * Combination of voice building blocks extends the duration of playback
- * Voice data re-use saves memory space
- * Four trigger pins, TG1 to TG4 for eight groups
- * SBT for sequential play-all
- # Holdable and unholdable, edge and level triggering option
- * 15 ms debounce time suitable for CDS
- * IRP interrupt pin for master reset
- * Three programmable output pins for STP Stop Pulse, BUSY Signal, and LED
- * Built-in oscillator with variable sample rate
- * Single external resistor to determine sample rate
- * Built-in D/A converter, EPROM
- * ADPCM data compression provides high sound quality
- * Optional pop noise elimination function
- * C_{OUT} pin drives speaker with a transistor
- # V_{OUT1} and V_{OUT2} drives buzzer or speaker directly
- * Auto-power down
- * 3.0V-6V single power supply operation
- * Low standby current (<5 A at 3V)
- * Development tools support

GENERAL DESCRIPTION

API8108A is a high quality voice synthesizer capable of varying playback duration. A proprietary ADPCM algorithm is used. The audio message is stored in a 256K bits on-chip EPROM which can store up to ten seconds of voice data at 6 KHz sample rate.

The API8108A eliminates the need of complicated circuitry in voice playback but still achieves high voice quality. Sounds such as human speech, animal sounds, musical sounds and even special sound effects can be synthesized. Versatile combinations in sections achieve longer playback duration. In addition, devices can be cascaded to achieve longer voice duration. Two devices can be configured in parallel in order to achieve signal mixing without an external mixer in which speech can be mixed with background music each from one of two different chips.

The API8108A provides wide operating voltage range from 2.8V to 6.0V. PWM digital amplifier output pins, V_{OUT1} and V_{OUT2} provides direct drive to buzzer or speaker.

A current output pin, C_{OUT}, enables the device to drive a speaker through a low cost NPN transistor. No complex filtering or amplifier circuit is needed. An automatic ramp-down function eliminates undesired noise at the end of playback.

Group of sections

The voice data memory area of the API8108A can be subdivided into 124 sections. Any combination of these sections will form an individual group for data playback. A maximum of eight groups are available with activation controlled by TG1 to TG4 pins. The SBT pin can be used to trigger multiple groups playback in sequence.

Group Configuration

Voice within each group are combinations of different fixed memory sections of up to 124 sections. These sections are the fundamental voice building blocks for arranging playback without limiting sequencing. This provides flexibility and allows data to be re-used, beneficial for applications with many repeated sounds or words.

An example of group configuration is illustrated below:

Group No.	Section Entry
Group 1	Sec 1 + Sec 2 + Sec 3 ----- Sec 109
Group 2	Sec 3 + Sec 2
Group 3	Sec 10 + Sec 11 + Sec 12
Group 4	Sec 110 + Sec 10 + Sec 5

Group Configuration *(continued)*

The entry of sections for each group is truly random and without limitation. However, there is a limit in the total number of entries for eight groups, which is 992 in the API8108A. It is acceptable to allocate all entries into only one group or distribute out to other groups. It depends on how many groups of messages are required.

Programmable Options

Groups in API8108A can have independent options. They include:

- * Edge or Level trigger
- * Unholdable or Holdable trigger
- * Retriggerable or non-retriggerable
- * LED1, LED2, Busy, and Stop pulse are configurable
- * Four selections in playback frequency

Selections in Triggering

The API8108A can be triggered in different ways, Edge or Level trigger, Holdable or Unholdable, Retriggerable or Non-retriggerable. The combinations of the triggering options provide versatile playback.

By enabling Retrigger, the playback can be controlled in Stop and Start mode. A trigger on any trigger pin will stop the content message and start the next message immediately.

Selections in Playback Frequency

This option provides four choices for each group in frequency which implies it is possible to have four different sampling rates in one chip or one sample rate with a different playback

frequency. As a matter of fact, the available choices are also dependent on the pullup resistor value at the OSC pin. For example, if the fundamental frequency choice is F, it can provide choices in $x1$, $x1-1/2$, $x2$, $x3$.

Selections in Output Buffer

There are three independent output pins, OUT1, OUT2, and OUT3, available for several combinations of LED1, LED2, Stop Pulse, and Busy Signal for each group. The following table illustrates the four different combinations.

	OUT1	OUT2	OUT3
1.	LED1	Busy	LED2
2.	Stop	LED2	LED1
3.	Busy	LED1	Stop
4.	LED2	Stop	Busy

LED1 and LED2 are complemented outputs flashing at approximately a 3 Hz rate. Stop pulse (STOP) gives a 15 ms positive pulse at the end of the playback for each Group with option have or do not have the Stop pulse.

Busy is active high and Section dependent but not Group dependent. Even if same section in different group may have different output in Busy output. For instance, BUSY can be high for Section 4 in Group 1 but low in Group 4. BUSY can be used as a synchronous signal. During standby mode all three outputs must be low.

Software Support

APLUS provides dedicated software to the customer. With this tool, the customer can compose their own messages and configure the chip to fit into their applications very easily.

BLOCK DIAGRAM

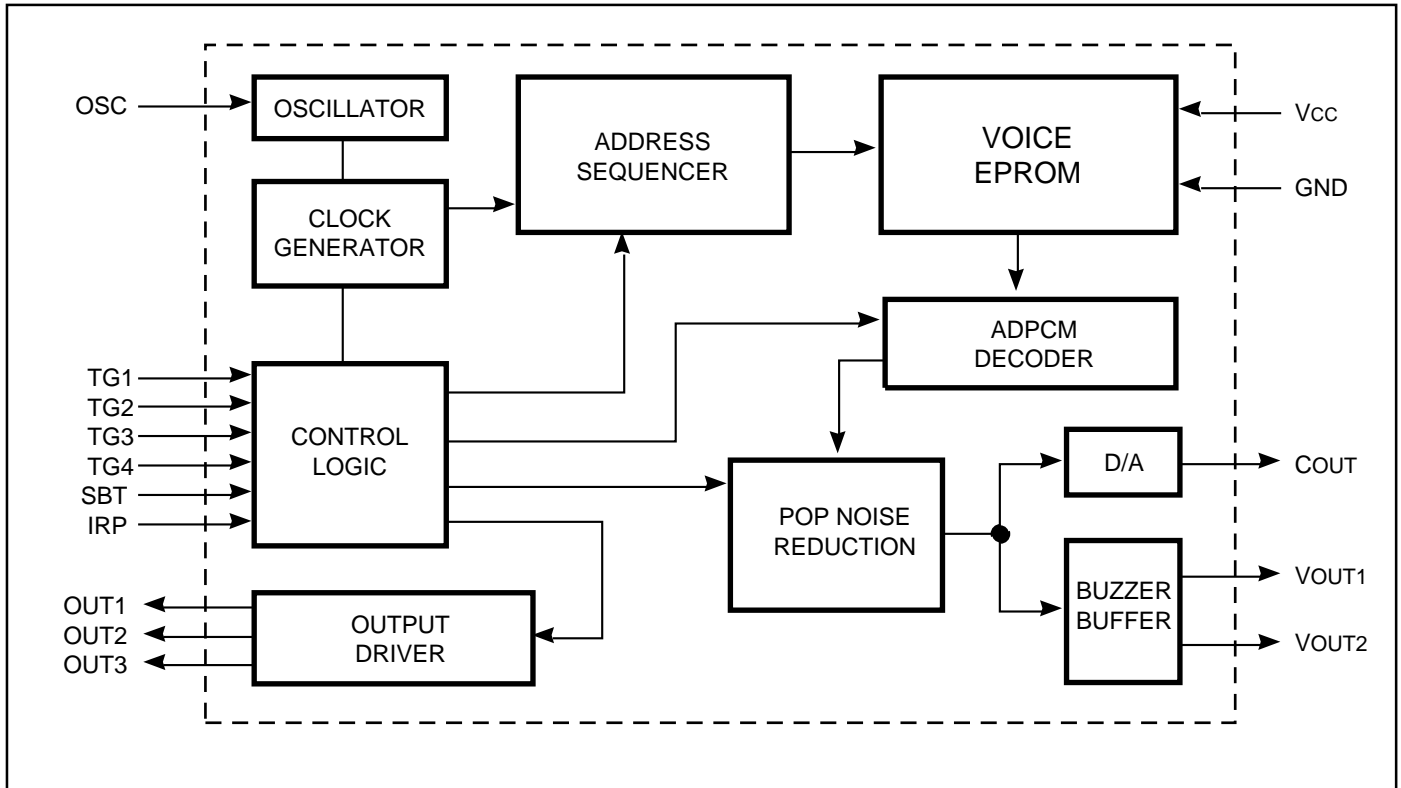

PIN CONFIGURATIONS

300-mil PDIP

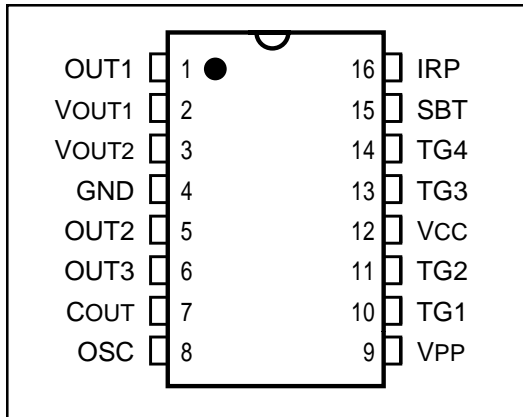

PIN DESCRIPTION

OUT1	Programmable output 1
OUT2	Programmable output 2
OUT3	Programmable output 3
VOUT1	PWM audio signal output for buzzer and speaker
VOUT2	PWM audio signal output for buzzer and speaker
GND	Power ground
COUT	Current output from internal DAC for speaker playback
OSC	Oscillator resistor pin to control sampling frequency
VPP	Program power supply, no connect when voice playback
TG1	Trigger switch 1, internal pull low, active high
TG2	Trigger switch 2, internal pull low, active high
Vcc	Positive power supply
TG3	Trigger switch 3, internal pull low, active high
TG4	Trigger switch 4, internal pull low, active high
SBT	Sequential trigger, internal pull low, active high
IRP	Interrupt to stop playback, internal pull low, active high

Note:

- The following pins are used to program data into the memory: pins 4, 5, 6, 8, 9, 12, 15 and 16.

BONDING DIAGRAM

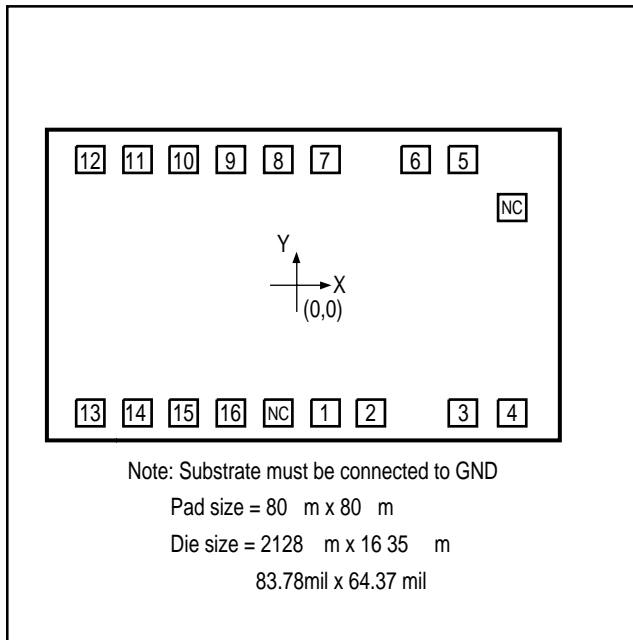

Note: Programming requires connection to pins 4, 5, 6, 8, 9, 12, 15, and 16.

BONDING PARAMETERS

Pin	Name	X	Y
1	OUT1	204	-678
2	VOUT1	423	-678
3	VOUT2	718	-678
4	GND	893	-678
5	OUT2	786	677
6	OUT3	590	677
7	COUT	167	677
8	OSC	-89	677
9	VPP	-306	677
10	TG1	-483	677
11	TG2	-691	677
12	Vcc	-899	677
13	TG3	-796	-678
14	TG4	-588	-678
15	SBT	-380	-678
16	IRP	-172	-678

ABSOLUTE MAXIMUM RATINGS

Symbol	Parameter	Value	Unit
V _{CC} - GND	Terminal Voltage with Respect to GND	-0.5 to +7.0	V
V _{IN}		GND -0.3 < V _{IN} < V _{CC} + 0.3	V
V _{OUT}		GND < V _{OUT} < V _{CC}	V
T _A	Operating Temperature	-10 to +85	°C
T _{STG}	Storage Temperature	-55 to +125	°C

DC CHARACTERISTICS

Symbol	Parameter Description	Test Conditions	Min.	Typ.	Max.	Unit
V _{CC}	Operating Voltage		3.0	4.5	6.0	V
I _{SB}	Standby Current	V _{CC} = 3.0V, I/O Open	-	1	5	uA
I _{OP}	Operating Current	V _{CC} = 3.0V, I/O Open	-	-	100	uA
V _{IH}	Input HIGH Voltage	V _{CC} = 3.0V	2.5	3.0	3.5	V
V _{IL}	Input LOW Voltage	V _{CC} = 2.0V	-0.3	0	0.3	V
I _{OH}	V _{OUT} HIGH Operating Current	V _{CC} = 3.0V, V _{OUT} = 3.0V	-	-12	-	mA
I _{OL}	V _{OUT} LOW Operating Current	V _{CC} = 3.0V, V _{OUT} = 0V	-	12	-	mA
I _{CO}	C _{OUT} Operating Current	V _{CC} = 3.0V, V _{COUT} = 0.7V	-	-2	-	mA
I _{STPH}	STP HIGH Operating Current	V _{CC} = 3.0V, V _{STP} = 3.0V	-	-5	-	mA
I _{STPL}	STP LOW Operating Current	V _{CC} = 3.0V, V _{STP} = 0V	-	5	-	mA
I _{LED}	LED Output Current	V _{CC} = 2.2V - 6.0V	6	8	10	mA
F/F	Frequency Stability	(F _{osc} [3V] - F _{osc} [3.5V]) / F _{osc} (3.0V)	-	-	5	%

TIMING WAVEFORMS

1. Level, Unholdable, Non-retriggerable

a. Trigger is shorter than a Group output

b. Trigger is longer than a Group output

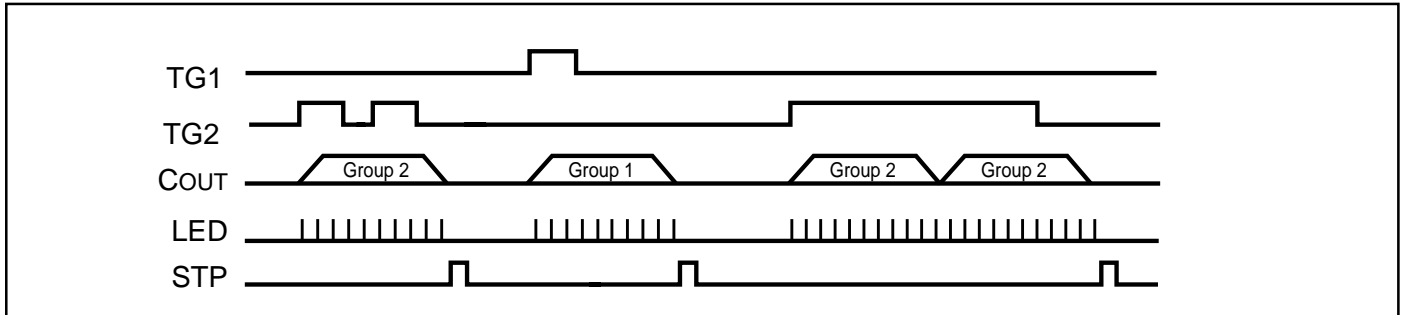

2. Level Holdable

a. Trigger is shorter than a Group output

b. Trigger is longer than a Group output

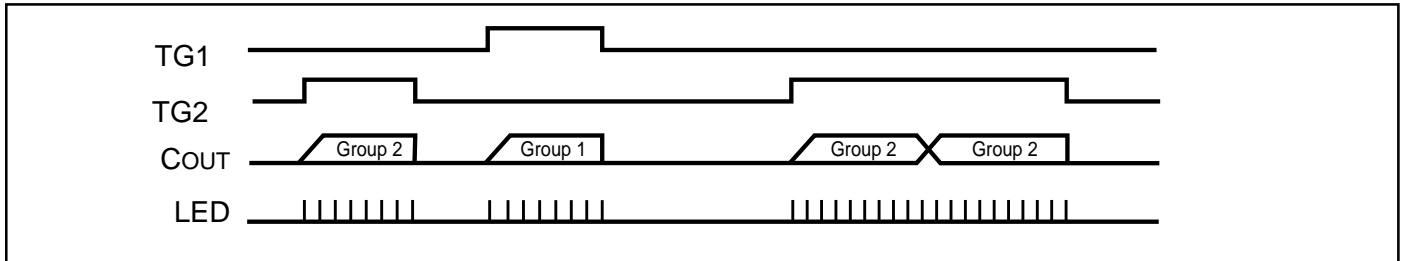

3. Single Button Trigger (SBT), Sequential

a. Level Unholdable

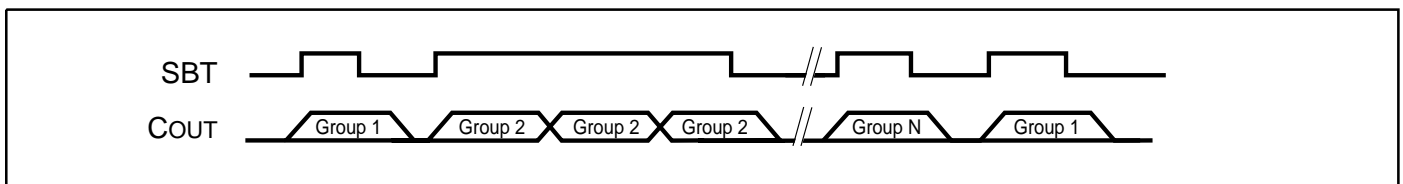

b. Level Holdable

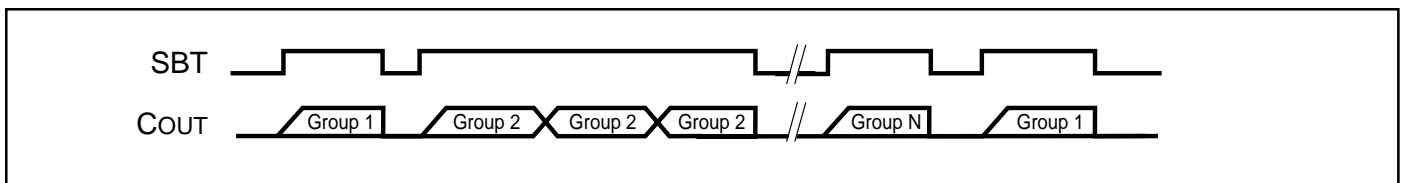

Where N is up to 8.

4. Edge, Unholdable, Non-retriggerable

- a. Trigger is shorter than a phrase output b. Trigger is longer than a phrase output

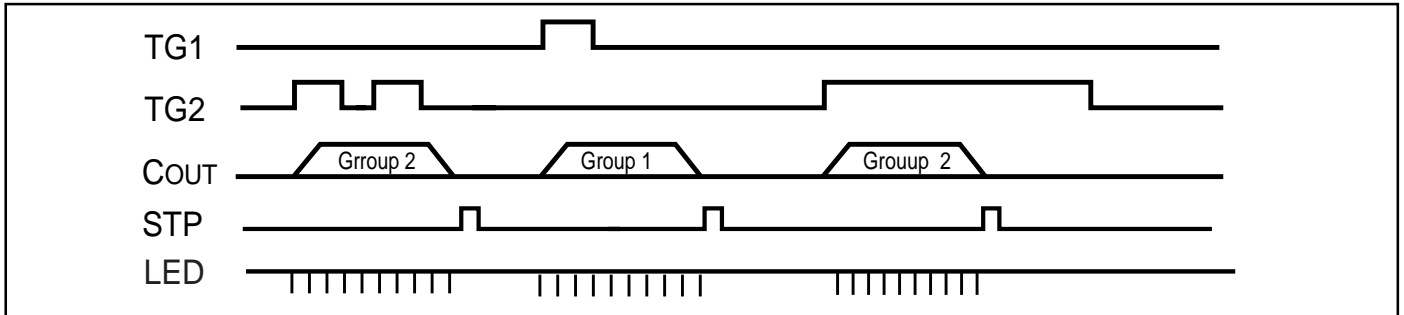

5. Edge Holdable

- a. Trigger is shorter than a phrase output b. Trigger is longer than a phrase output

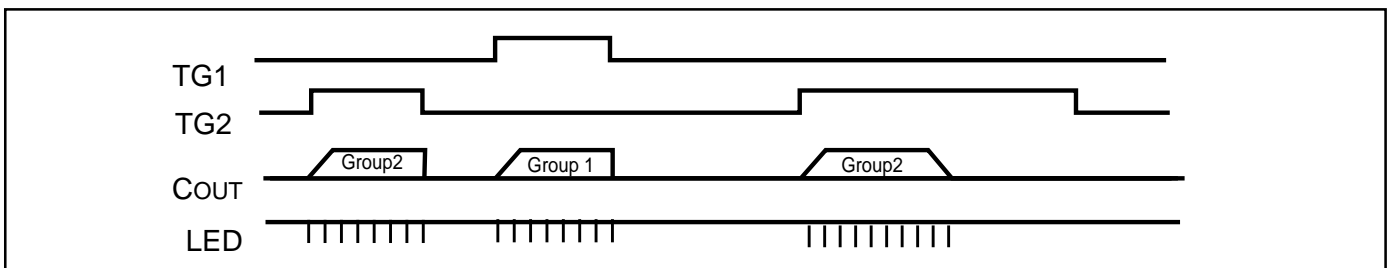

6. Single Button Trigger (SBT), Sequential

a. Edge Unholdable

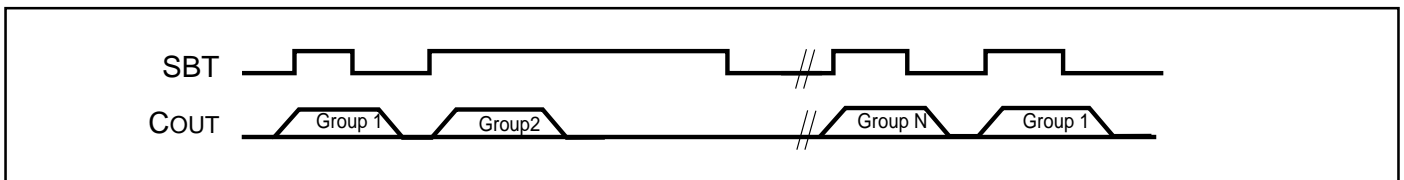

b. Edge Holdable

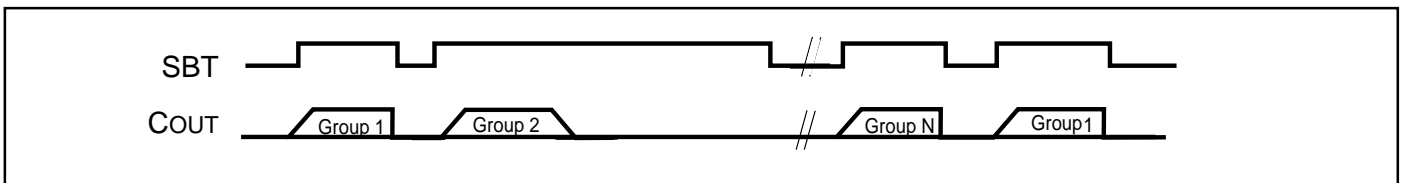

Where N is up to 8.

APPLICATION CIRCUITS

TYPICAL APPLICATION

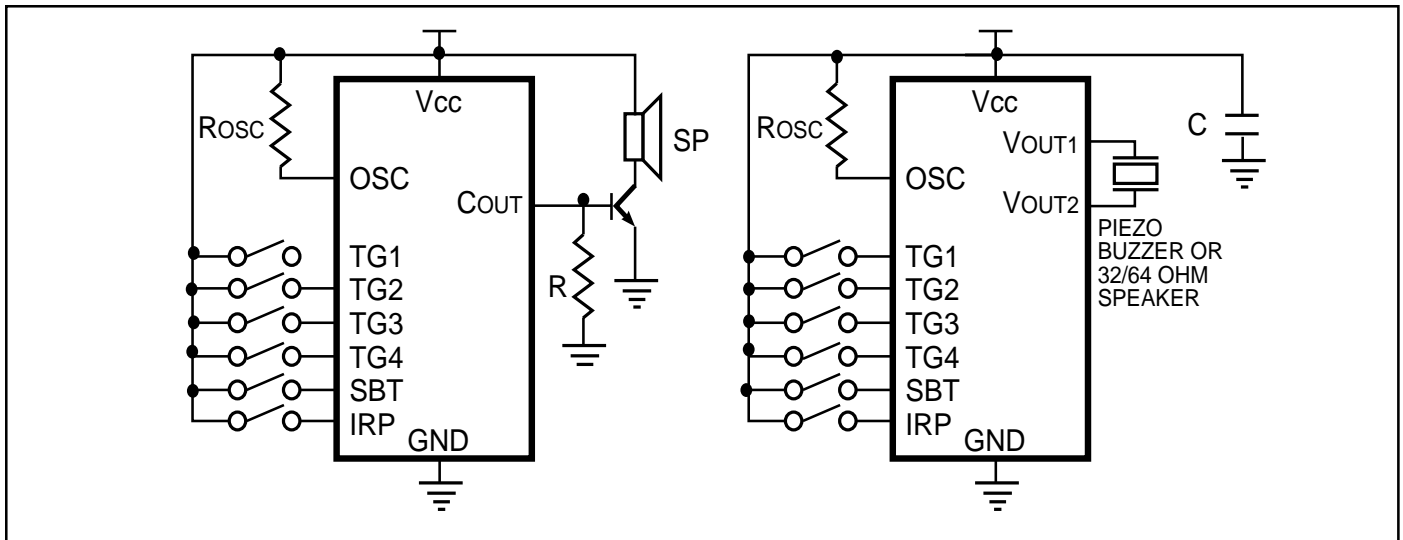

CASCADE APPLICATION

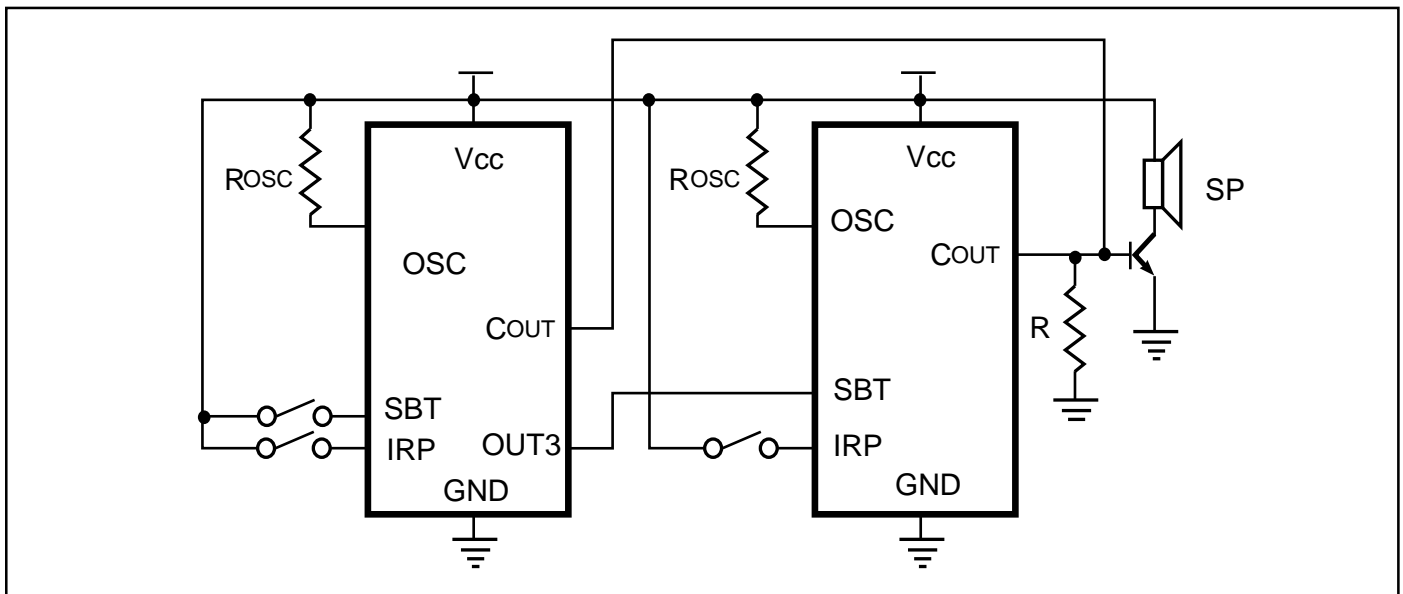

Notes:

1. To direct drive a speaker or buzzer, C is needed ($C = 0.1 \mu\text{F}$).
2. $R = 330 \text{ Ohm}$ (if using transistor 8050 and $V_{cc} = 4.5\text{V}$).
3. $SP = 8 \text{ Ohm}$ speaker.
4. To determine the value of R_{osc} , refer to the Sampling Frequency vs. R_{osc} tables on page 6.

APPLICATION CIRCUITS

PARALLEL APPLICATION

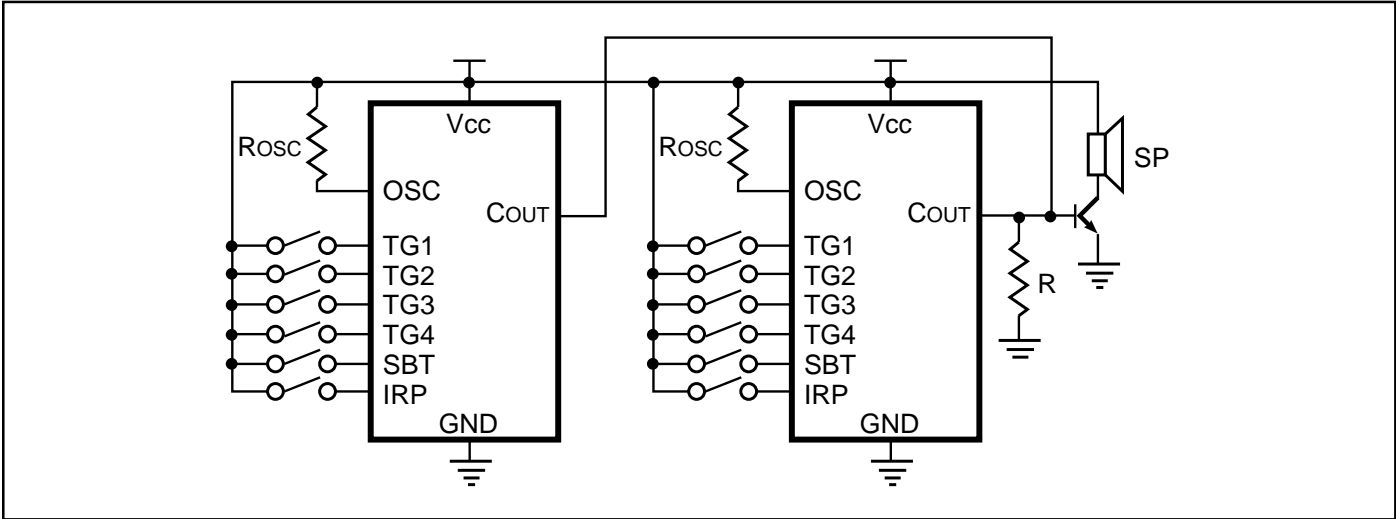

LED APPLICATION

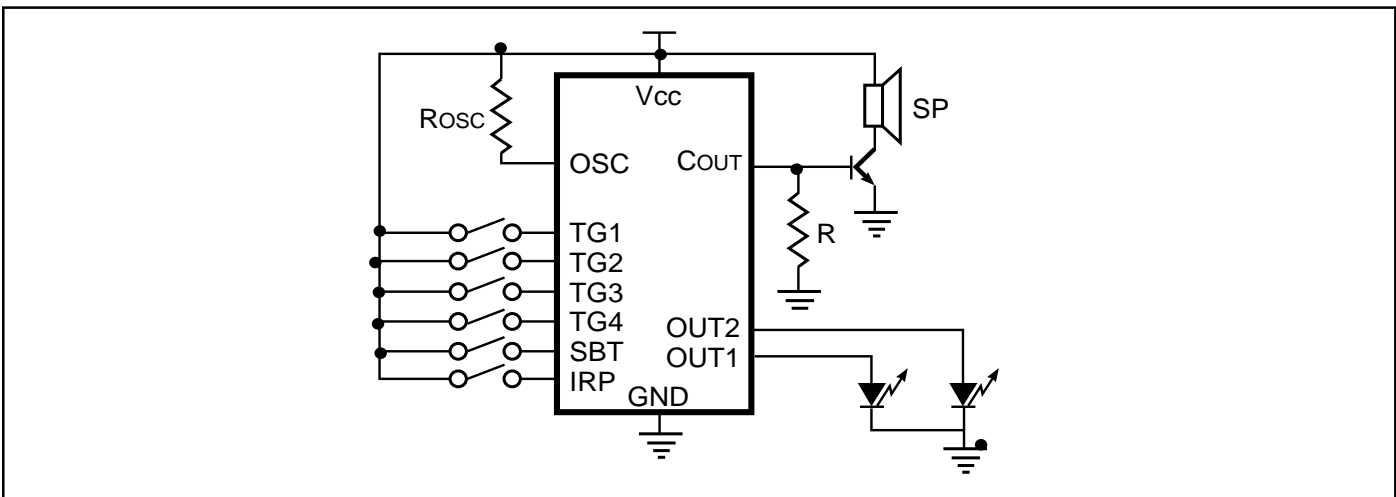

Notes:

The following are typical values:

1. B of NPN transistor > 130.
2. SP = 8 Ω, 1/4W.
3. Piezo buzzer resonant frequency = 1 KHz.

APPLICATION CIRCUITS

CDS APPLICATION

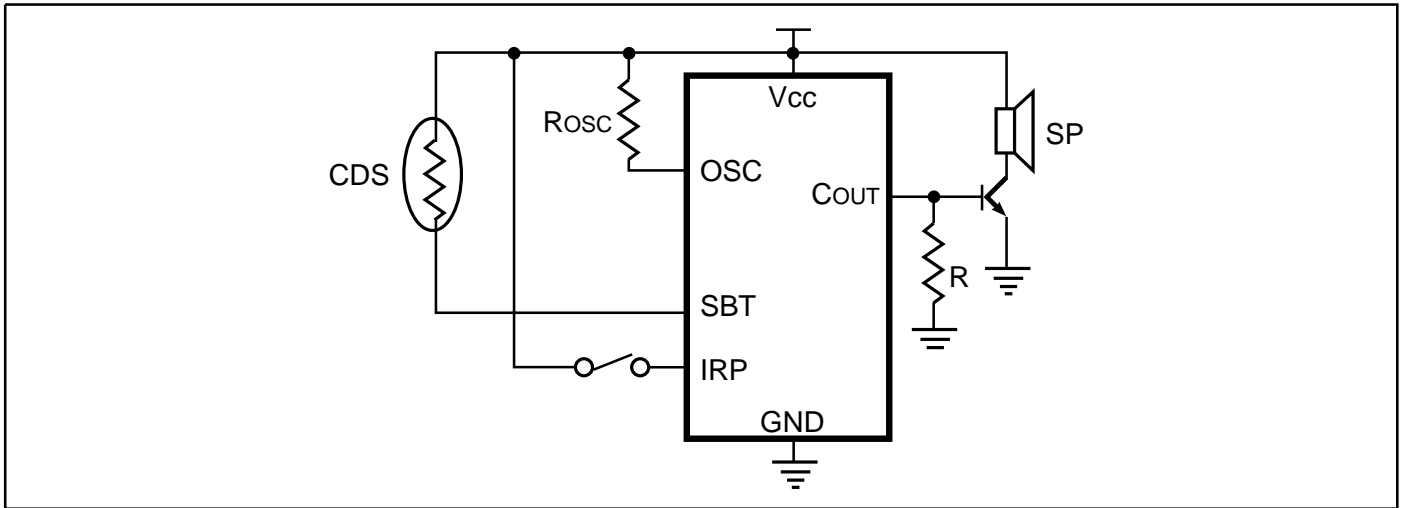

8-SEGMENT TRIGGER APPLICATION

