

# AZ10E131

# AZ100E131

## ECL/PECL 4-bit D Flip-Flop

### FEATURES

- 1100 MHz Min. Toggle Frequency
- Differential Outputs
- Individual and Common Clocks
- Individual Resets (asynchronous)
- Paired Sets (asynchronous)
- Operating Range of 4.2V to 5.46V
- 75kΩ Internal Input Pulldown Resistors
- Direct Replacement for On Semiconductor MC10E131 & MC100E131

### PACKAGE AVAILABILITY

PACKAGE	PART NUMBER	MARKING	NOTES
PLCC 28	AZ10E131FN	AZM10E131 <Date Code>	1,2
PLCC 28	AZ100E131FN	AZM100E131 <Date Code>	1,2

- 1 Add R2 at end of part number for 13 inch (2.5K parts) Tape & Reel.  
 2 Date code format: "YY" for year followed by "WW" for week.

### DESCRIPTION

The AZ10/100E131 is a quad master-slave D-type flip-flop with differential outputs. Each flip-flop may be clocked separately by holding Common Clock ( $C_C$ ) LOW and using the Clock Enable ( $\overline{CEN}$ ) inputs for clocking. Common clocking is achieved by holding the  $\overline{CEN}$  inputs LOW and using  $C_C$  to clock all four flip-flops. In this case, the  $\overline{CEN}$  inputs perform the function of controlling the common clock to each flip-flop.

Individual asynchronous resets are provided ( $R_n$ ). Asynchronous set controls ( $S_n$ ) are ganged together in pairs, with the pairing chosen to reflect physical chip symmetry.

Data enters the master when both  $C_C$  and  $\overline{CEN}$  are LOW, and transfers to the slave when either  $C_C$  or  $\overline{CEN}$  (or both) go HIGH.

NOTE: Specifications in ECL/PECL tables are valid when thermal equilibrium is established.

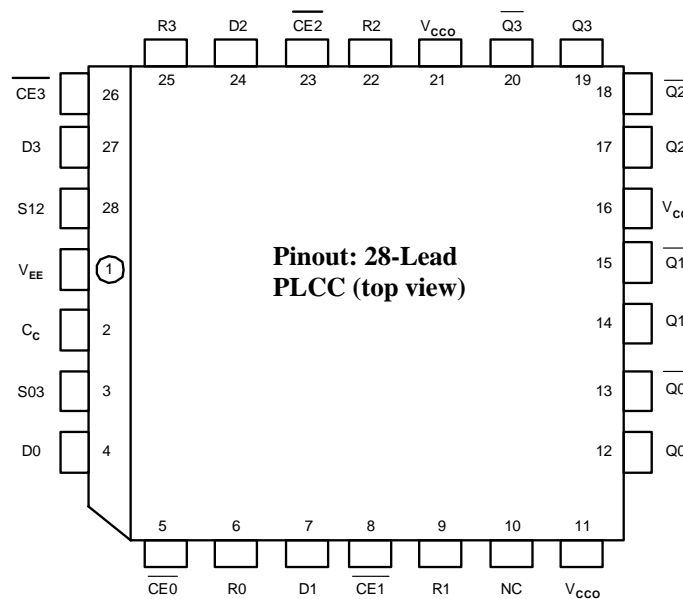

\* All  $V_{CC}$  and  $V_{CC0}$  pins are tied together on the die.

**AZ10E131**  
**AZ100E131**

**PIN DESCRIPTION**

PIN	FUNCTION
D0 – D3	Data inputs
CE0 – CE3	Clock Enables (Individual)
R0 – R3	Resets
C <sub>C</sub>	Common Clock
S03,S12	Sets (paired)
Q0 – Q3	True Outputs
Q̄0 – Q̄3	Inverting Outputs
V <sub>CC</sub> , V <sub>CC0</sub>	Positive Supply
V <sub>EE</sub>	Negative Supply
NC	No connect

**LOGIC SYMBOL**

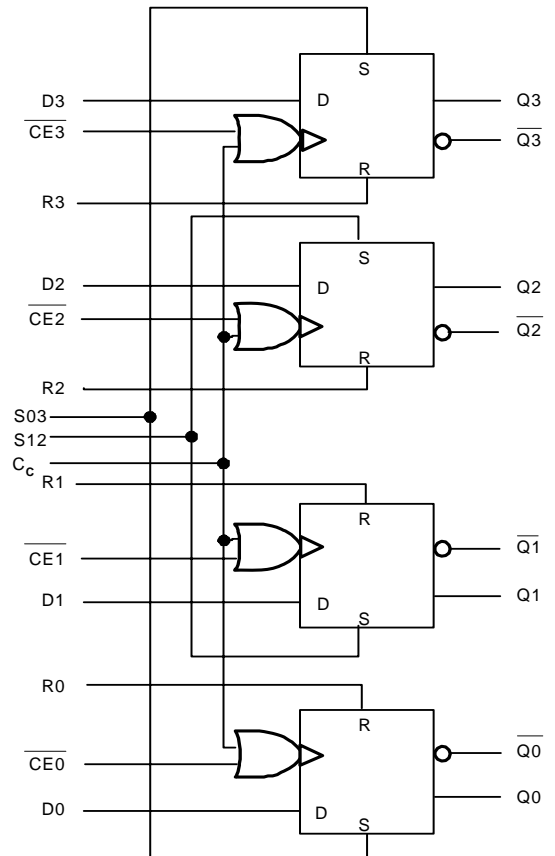

**Absolute Maximum Ratings are those values beyond which device life may be impaired.**

Symbol	Characteristic	Rating	Unit
V <sub>CC</sub>	PECL Power Supply (V <sub>EE</sub> = 0V)	0 to +8.0	Vdc
V <sub>I</sub>	PECL Input Voltage (V <sub>EE</sub> = 0V)	0 to +6.0	Vdc
V <sub>EE</sub>	ECL Power Supply (V <sub>CC</sub> = 0V)	-8.0 to 0	Vdc
V <sub>I</sub>	ECL Input Voltage (V <sub>CC</sub> = 0V)	-6.0 to 0	Vdc
I <sub>OUT</sub>	Output Current --- Continuous --- Surge	50 100	mA
T <sub>A</sub>	Operating Temperature Range	-40 to +85	°C
T <sub>STG</sub>	Storage Temperature Range	-65 to +150	°C

**10K ECL DC Characteristics (V<sub>EE</sub> = -4.94V to -5.46V, V<sub>CC</sub> = V<sub>CC0</sub> = GND)**

Symbol	Characteristic	-40°C			0°C			25°C			85°C			Unit
		Min	Typ	Max	Min	Typ	Max	Min	Typ	Max	Min	Typ	Max	
V <sub>OH</sub>	Output HIGH Voltage <sup>1</sup>	-1080		-890	-1020		-840	-980		-810	-910		-720	mV
V <sub>OL</sub>	Output LOW Voltage <sup>1</sup>	-1950		-1650	-1950		-1630	-1950		-1630	-1950		-1595	mV
V <sub>IH</sub>	Input HIGH Voltage	-1230		-890	-1170		-840	-1130		-810	-1060		-720	mV
V <sub>IL</sub>	Input LOW Voltage	-1950		-1500	-1950		-1480	-1950		-1480	-1950		-1445	mV
I <sub>IH</sub>	Input HIGH Current													μA
	C <sub>C</sub>			350			350			350			350	
	S			450			450			450			450	
	R, CE			300			300			300			300	
	D			150			150			150			150	
I <sub>IL</sub>	Input LOW Current	0.5			0.5			0.5			0.5			μA
I <sub>EE</sub>	Power Supply Current		58	70		58	70		58	70		58	70	mA

1. Each output is terminated through a 50Ω resistor to V<sub>CC</sub> - 2V.

**AZ10E131**  
**AZ100E131**

**10K PECL DC Characteristics** ( $V_{EE} = \text{GND}$ ,  $V_{CC} = V_{CCO} = +5.0\text{V}$ )

Symbol	Characteristic	-40°C			0°C			25°C			85°C			Unit
		Min	Typ	Max	Min	Typ	Max	Min	Typ	Max	Min	Typ	Max	
$V_{OH}$	Output HIGH Voltage <sup>1,2</sup>	3920		4110	3980		4160	4020		4190	4090		4280	mV
$V_{OL}$	Output LOW Voltage <sup>1,2</sup>	3050		3350	3050		3370	3050		3370	3050		3405	mV
$V_{IH}$	Input HIGH Voltage <sup>1</sup>	3770		4110	3830		4160	3870		4190	3940		4280	mV
$V_{IL}$	Input LOW Voltage <sup>1</sup>	3050		3500	3050		3520	3050		3520	3050		3555	mV
$I_{IH}$	Input HIGH Current C <sub>C</sub> S R, CE D			350			350			350			350	μA
				450			450			450			450	
				300			300			300			300	
				150			150			150			150	
$I_{IL}$	Input LOW Current	0.5			0.5			0.5			0.5			μA
$I_{EE}$	Power Supply Current		58	70		58	70		58	70		58	70	mA

- For supply voltages other than 5.0V, use the ECL table values and ADD supply voltage value.
- Each output is terminated through a 50Ω resistor to  $V_{CC} - 2\text{V}$ .

**100K ECL DC Characteristics** ( $V_{EE} = -4.2\text{V}$  to  $-5.46\text{V}$ ,  $V_{CC} = V_{CCO} = \text{GND}$ )

Symbol	Characteristic	-40°C			0°C			25°C			85°C			Unit
		Min	Typ	Max	Min	Typ	Max	Min	Typ	Max	Min	Typ	Max	
$V_{OH}$	Output HIGH Voltage <sup>1</sup>	-1085	-1005	-880	-1025	-955	-880	-1025	-955	-880	-1025	-955	-880	mV
$V_{OL}$	Output LOW Voltage <sup>1</sup>	-1830	-1695	-1555	-1810	-1705	-1620	-1810	-1705	-1620	-1810	-1705	-1620	mV
$V_{IH}$	Input HIGH Voltage	-1165		-880	-1165		-880	-1165		-880	-1165		-880	mV
$V_{IL}$	Input LOW Voltage	-1810		-1475	-1810		-1475	-1810		-1475	-1810		-1475	mV
$I_{IH}$	Input HIGH Current C <sub>C</sub> S R, CE D			350			350			350			350	μA
				450			450			450			450	
				300			300			300			300	
				150			150			150			150	
$I_{IL}$	Input LOW Current	0.5			0.5			0.5			0.5			μA
$I_{EE}$	Power Supply Current		58	70		58	70		58	70		67	81	mA

- Each output is terminated through a 50Ω resistor to  $V_{CC} - 2\text{V}$ .

**100K PECL DC Characteristics** ( $V_{EE} = \text{GND}$ ,  $V_{CC} = V_{CCO} = +5.0\text{V}$ )

Symbol	Characteristic	-40°C			0°C			25°C			85°C			Unit
		Min	Typ	Max	Min	Typ	Max	Min	Typ	Max	Min	Typ	Max	
$V_{OH}$	Output HIGH Voltage <sup>1,2</sup>	3915	3995	4120	3975	4045	4120	3975	4045	4120	3975	4045	4120	mV
$V_{OL}$	Output LOW Voltage <sup>1,2</sup>	3170	3305	3445	3190	3295	3380	3190	3295	3380	3190	3295	3380	mV
$V_{IH}$	Input HIGH Voltage <sup>1</sup>	3835		4120	3835		4120	3835		4120	3835		4120	mV
$V_{IL}$	Input LOW Voltage <sup>1</sup>	3190		3525	3190		3525	3190		3525	3190		3525	mV
$I_{IH}$	Input HIGH Current C <sub>C</sub> S R, CE D			350			350			350			350	μA
				450			450			450			450	
				300			300			300			300	
				150			150			150			150	
$I_{IL}$	Input LOW Current	0.5			0.5			0.5			0.5			μA
$I_{EE}$	Power Supply Current		58	70		58	70		58	70		67	81	mA

- For supply voltages other than 5.0V, use the ECL table values and ADD supply voltage value.
- Each output is terminated through a 50Ω resistor to  $V_{CC} - 2\text{V}$ .

**AZ10E131**  
**AZ100E131**

**AC Characteristics** ( $V_{EE} = 10E(-4.94V \text{ to } -5.46V)$ ,  $100E(-4.2V \text{ to } -5.46V)$ ;  $V_{CC} = V_{CCO} = GND$  or  $V_{EE} = GND$ ,  
 $V_{CC} = V_{CCO} = 10E(+4.94V \text{ to } +5.46V)$ ,  $100E(+4.2V \text{ to } +5.46V)$ )

Symbol	Characteristic	-40°C			0°C			25°C			85°C			Unit	
		Min	Typ	Max	Min	Typ	Max	Min	Typ	Max	Min	Typ	Max		
$F_{max}$	Max. Toggle Frequency	1100	1400		1100	1400		1100	1400		1100	1400		MHz	
$t_{PLH} / t_{PHL}$	Propagation Delay to Output	CE	310	600	750	360	500	700	360	500	700	360	500	700	ps
		$C_C$	275	600	725	325	500	675	325	500	675	325	500	675	
		R	300	620	775	350	550	725	350	550	725	350	550	725	
		S	300	550	775	350	550	725	350	550	725	350	550	725	
$t_S$	Setup Time <sup>2</sup>	D	200	20		150	20		150	20		150	20	ps	
$t_H$	Hold Time <sup>2</sup>	D	225	-20		175	-20		175	-20		175	-20	ps	
$t_{RR}$	Reset Recovery Time		450	150		400	150		400	150		400	150	ps	
$t_{PW}$	Minimum Pulse Width CLK, S, R		400			400			400			400		ps	
$t_{SKEW}$	Within-Device Skew <sup>1</sup>			60			60			60			60	ps	
$t_r / t_f$	Rise/Fall Times 20% - 80%		275		725	300		675	300		675	300		ps	

1. Within-device skew is defined as identical transitions on similar paths through a device.
2. Setup/hold times guaranteed for both  $C_C$  & CE.

AZ10E131  
AZ100E131

**PACKAGE DIAGRAM  
PLCC 28**

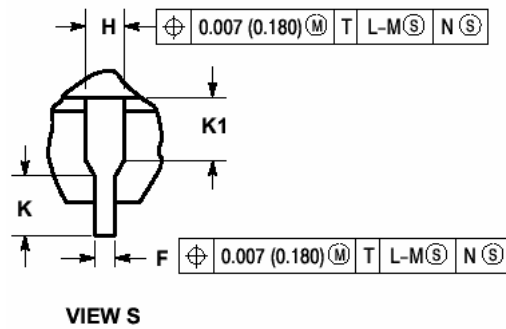
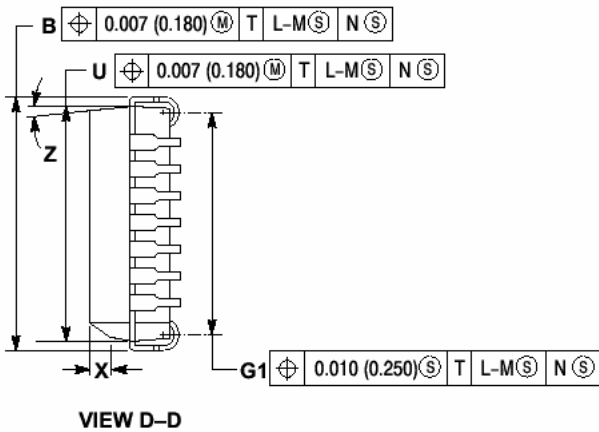
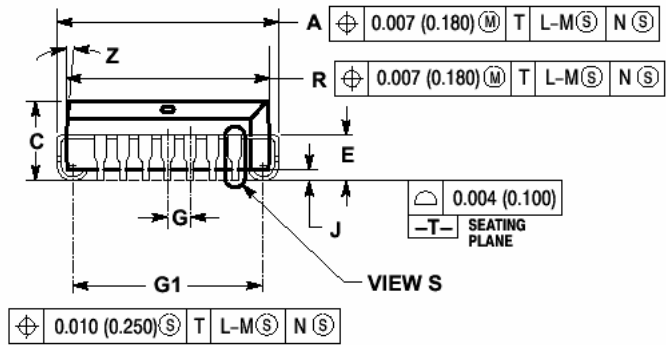
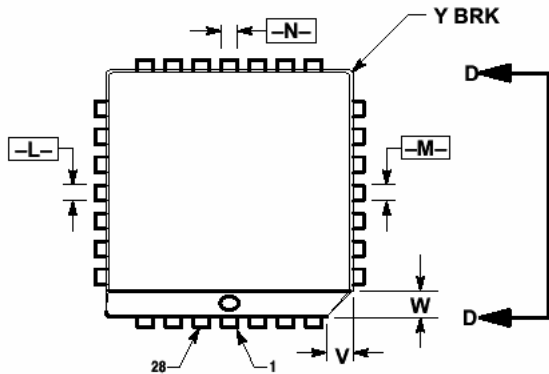

DIM	MILLIMETERS		INCHES	
	MIN	MAX	MIN	MAX
A	12.32	12.57	0.485	0.495
B	12.32	12.57	0.485	0.495
C	4.20	4.57	0.165	0.180
E	2.29	2.79	0.090	0.110
F	0.33	0.48	0.013	0.019
G	1.27 BSC		0.050 BSC	
H	0.66	0.81	0.026	0.032
J	0.51		0.020	
K	0.64		0.025	
R	11.43	11.58	0.450	0.456
U	11.43	11.58	0.450	0.456
V	1.07	1.21	0.042	0.048
W	1.07	1.21	0.042	0.048
X	1.07	1.42	0.042	0.056
T		0.50		0.020
Z	2°	10°	2°	10°
G1	10.42	10.92	0.410	0.430
K1	1.02		0.040	

NOTES:

- DATUMS -L-, -M-, AND -N- DETERMINED WHERE TOP OF LEAD SHOULDER EXITS PLASTIC BODY AT MOLD PARTING LINE.
- DIMENSION G1, TRUE POSITION TO BE MEASURED AT DATUM -T-, SEATING PLANE.
- DIMENSIONS R AND U DO NOT INCLUDE MOLD FLASH. ALLOWABLE MOLD FLASH IS 0.010mm (0.250in.) PER SIDE.
- DIMENSIONING AND TOLERANCING PER ANSI Y14.5M, 1982.
- CONTROLLING DIMENSION: INCH.
- THE PACKAGE TOP MAY BE SMALLER THAN THE PACKAGE BOTTOM BY UP TO 0.012mm (0.300in.). DIMENSIONS R AND U ARE DETERMINED AT THE OUTERMOST EXTREMES OF THE PLASTIC BODY EXCLUSIVE OF MOLD FLASH, THE BAR BURRS, GATE BURRS AND INTERLEAD FLASH, BUT INCLUDING ANY MISMATCH BETWEEN THE TOP AND BOTTOM OF THE PLASTIC BODY.
- DIMENSION H DOES NOT INCLUDE DAMBAR PROTRUSION OR INTRUSION. THE DAMBAR PROTRUSION(S) SHALL NOT CAUSE THE H DIMENSION TO BE SMALLER THAN 0.025mm (0.635in.).

**AZ10E131**  
**AZ100E131**

Arizona Microtek, Inc. reserves the right to change circuitry and specifications at any time without prior notice. Arizona Microtek, Inc. makes no warranty, representation or guarantee regarding the suitability of its products for any particular purpose, nor does Arizona Microtek, Inc. assume any liability arising out of the application or use of any product or circuit and specifically disclaims any and all liability, including without limitation special, consequential or incidental damages. Arizona Microtek, Inc. does not convey any license rights nor the rights of others. Arizona Microtek, Inc. products are not designed, intended or authorized for use as components in systems intended to support or sustain life, or for any other application in which the failure of the Arizona Microtek, Inc. product could create a situation where personal injury or death may occur. Should Buyer purchase or use Arizona Microtek, Inc. products for any such unintended or unauthorized application, Buyer shall indemnify and hold Arizona Microtek, Inc. and its officers, employees, subsidiaries, affiliates, and distributors harmless against all claims, costs, damages, and expenses, and reasonable attorney fees arising out of, directly or indirectly, any claim of personal injury or death associated with such unintended or unauthorized use, even if such claim alleges that Arizona Microtek, Inc. was negligent regarding the design or manufacture of the part.