

Thermopile Infrared Detectors

# Quad Thermopile **TPS 4339**

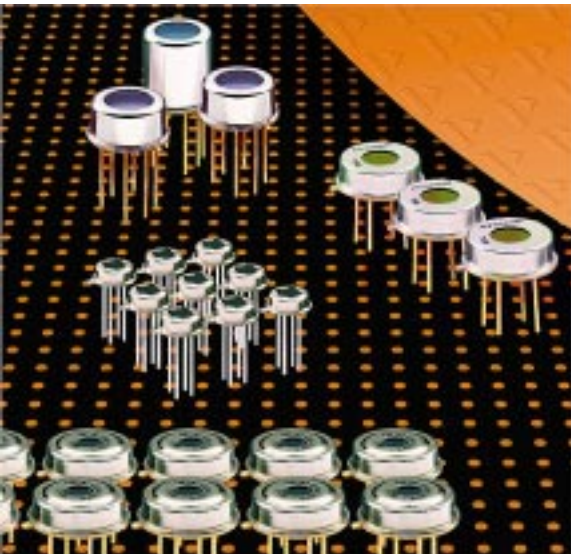

**Four individual thermopiles with different infrared bandpass filters in TO 5 housing for NDIR gas sensing – up to 4 gases possible**

**Thermistor temperature reference included**

**Internal aperture to avoid cross talk**

**Standard gas filter sets for reference, CO, hydrocarbon, CO<sub>2</sub>**

The quad thermopile sensor consists of four single thermopile chips mounted in a TO 5 housing with a thermistor as temperature reference. The window size is 1.5 x 1.5 mm<sup>2</sup> each. Due to the overall small sensor size the construction of a very compact equipment becomes possible.

Applications in automotive exhaust gas control, multiple gas detection for the safety product market or air quality monitoring

For further information please refer to the TPS 4339 product note

Parameters	TPS 4339		units	condition
	typical			
<b>Sensitive area</b>	4x 0.7 x 0.7		mm <sup>2</sup>	absorbing area
<b>Window size</b>	1.5 x 1.5		mm <sup>2</sup>	each channel
<b>DC sensitivity</b>	75		V/W	500K BB w/o filter
<b>Resistance</b>	75		kΩ	
<b>Noise</b>	21		nV/√Hz	r.m.s. 300K
<b>NEP</b>	0.28		nW/√Hz	500K BB w/o filter
<b>D*</b>	1.6 x 10 <sup>8</sup>		cm√Hz/W	500K BB w/o filter
<b>TC of sensitivity</b>	0.02		%/K	
<b>TC of resistance</b>	0.02		%/K	
<b>Time constant</b>	25		ms	
<b>Operating temperature</b>	-40	100	°C	non permanent
<b>Storage temperature</b>	-40	100	°C	non permanent
<b>Thermistor resistance</b>	100		kΩ	25°C
<b>beta</b>	3964		K	25°C/100°C
<b>Field of view</b>	4x 60		°	at 50% points

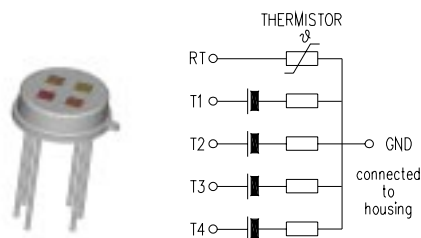

Right for modification reserved / WS / 5.7.2001

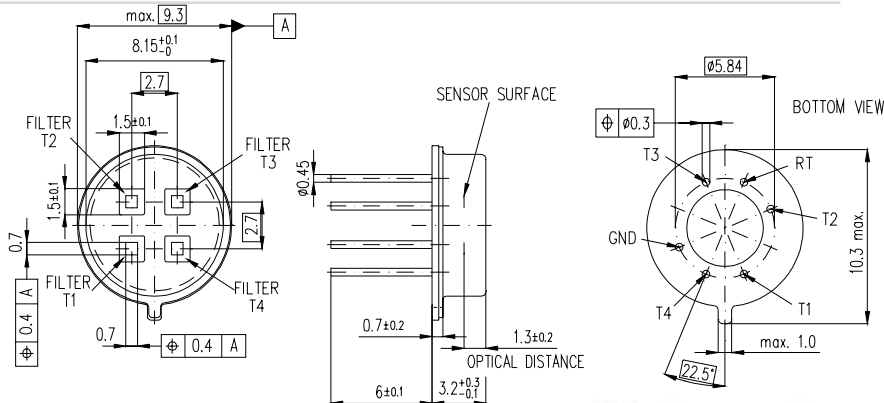
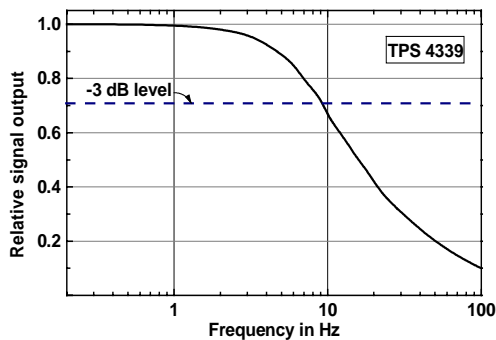
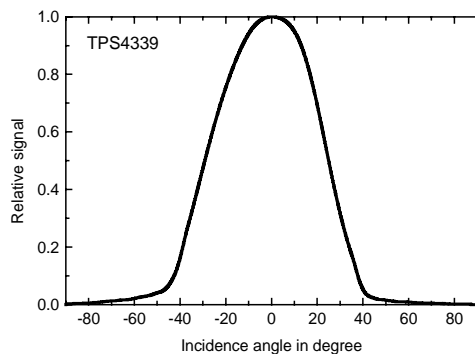

Europe:  
**PerkinElmer** Optoelectronics GmbH  
 Wenzel Jaksch Str 31  
 Wiesbaden / Germany  
 Phone +49(0)611 492 0  
 Fax +49(0)611 492 170

USA:  
**PerkinElmer** Optoelectronics  
 2175 Mission College Blvd  
 Santa Clara, CA 95054  
 Phone +408 565 0830  
 Fax +408 565 0703

Asia:  
**PerkinElmer** Optoelectronics  
 47, Ayer Rajah Crescent #06-12  
 Singapore 139947  
 Phone +65 775 2022  
 Fax +65 775 1008



DATASHEET