

2.4V -3.6V Differential inputs to HSTL outputs Clock Buffer

FEATURES:	DESCRIPTION:
<ul style="list-style-type: none"> • Patented Technology • Two HSTL differential outputs • One pair of LVDS/LVPECL/HSTL/ differential or single-ended inputs • Operating frequency up to 1.24GHz with 2pf load • Operating frequency up to 900MHz with 5pf load • Operating frequency up to 400MHz with 15pf load • Very low output pin to pin skew < 40ps • Propagation delay < 2.0ns max with 15pf load • 2.4V to 3.6V power supply • Industrial temperature range: -40°C to 85°C • Available in 8-pin SOIC package • Available in 8-pin TSSOP package 	<p>Potato Semiconductor's PO100HSTL11A is designed for world top performance using submicron CMOS technology to achieve 1.24GHz HSTL output frequency with less than 2.0ns propagation delay.</p> <p>The PO100HSTL11A is a low-skew, 1-to-2 differential fanout buffer targeted to meet the requirements of high-performance clock and data distribution applications. The device has a fully differential internal architecture that is optimized to achieve low signal skews at operating frequencies of up to 1.24GHz .</p>

Pin Configuration

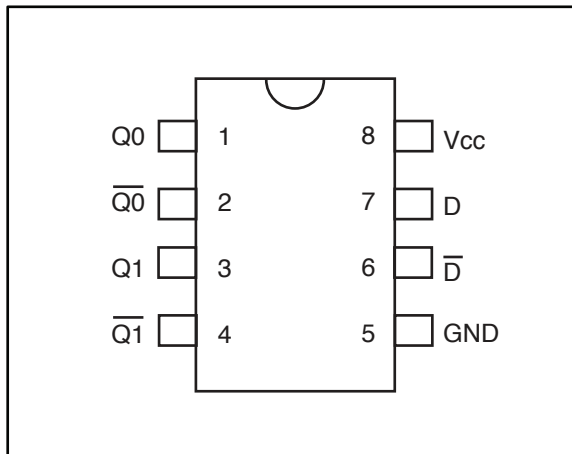

Logic Block Diagram

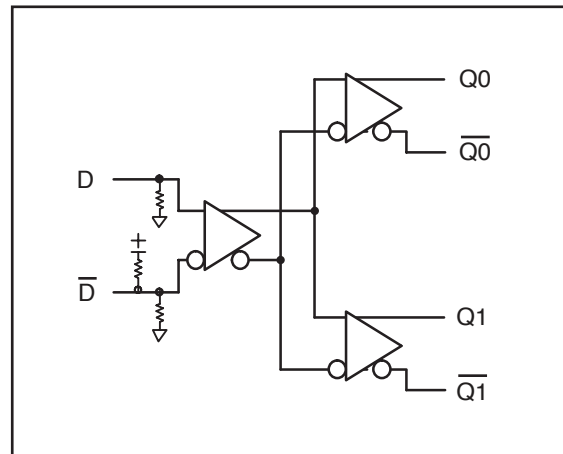

Pin Description

PIN	FUNCTION
D, \bar{D}	LVDS LVPECL HSTL Inputs
Q0, $\bar{Q0}$, Q1, $\bar{Q1}$	HSTL Outputs
V _{CC}	Positive Supply
GND	Ground Supply

2.4V -3.6V Differential inputs to HSTL outputs Clock Buffer

Maximum Ratings

Description	Max	Unit
Storage Temperature	-65 to 150	°C
Operation Temperature	-40 to 85	°C
Operation Voltage	-0.5 to +4.6	V
Input Voltage	-0.5 to Vcc	V
Output Voltage	-0.5 to Vcc+0.5	V

Note:

stresses greater than listed under Maximum Ratings may cause permanent damage to the device. This is a stress rating only and functional operation of the device at these or any other conditions above those indicated in the operational sections of this specification is not implied. Exposure to absolute maximum rating conditions for extended periods may affect reliability specification is not implied.

Pin Characteristics

Symbol	Parameter	Test Conditions	Minimum	Typical	Maximum	Units
C _{IN}	Input Capacitance			4		pF
R _{PULLUP}	Input Pullup Resistor			88		KΩ
R _{PULLDOWN}	Input Pulldown Resistor			88		KΩ

DC Electrical Characteristics

Symbol	Description	Test Conditions	Min	Typ	Max	Unit
V _{OH}	Output High voltage	Vcc=3V Vin=VIH or VIL, IOH= -12mA	2.4	3	-	V
V _{OL}	Output Low voltage	Vcc=3V Vin=VIH or VIL, IOH=12mA	-	0.3	0.5	V
V _{IH}	Input High voltage	Guaranteed Logic HIGH Level (Input Pin)	2	-	Vcc	V
V _{IL}	Input Low voltage	Guaranteed Logic LOW Level (Input Pin)	-0.5	-	0.8	V
I _{IH}	Input High current	Vcc = 3.6V and Vin = Vcc	-	-	1	uA
I _{IL}	Input Low current	Vcc = 3.6V and Vin = 0V	-	-	-1	uA
V _{IK}	Clamp diode voltage	Vcc = Min. And IIN = -18mA	-	-0.7	-1.2	V

Notes:

1. For conditions shown as Max. or Min., use appropriate value specified under Electrical Characteristics for the applicable device type.
2. Typical values are at Vcc = 3.3V, 25 °C ambient.
3. This parameter is guaranteed but not tested.
4. Not more than one output should be shorted at one time. Duration of the test should not exceed one second.
5. VoH = Vcc – 0.6V at rated current

2.4V -3.6V Differential inputs to HSTL outputs Clock Buffer

Power Supply Characteristics

Symbol	Description	Test Conditions (1)	Min	Typ	Max	Unit
I _{ccQ}	Quiescent Power Supply Current	V _{cc} =Max, V _{in} =V _{cc} or GND	-	0.1	30	uA

Notes:

1. For conditions shown as Max. or Min., use appropriate value specified under Electrical Characteristics for the applicable device type.
2. Typical values are at V_{cc} = 3.3V, 25°C ambient.
3. This parameter is guaranteed but not tested.
4. Not more than one output should be shorted at one time. Duration of the test should not exceed one second.

Switching Characteristics

Symbol	Description	Test Conditions (1)	Max	Unit
t _{PD}	Propagation Delay D to Output pair	CL = 15pF	2.0	ns
t _r /t _f	Rise/Fall Time	0.8V – 2.0V	0.8	ns
t _{sk(o)}	Output Pin to Pin Skew (Same Package)	CL = 15pF, 125MHz	40	ps
t _{sk(pp)}	Output Skew (Different Package)	CL = 15pF, 125MHz	250	ps
f _{max}	Input Frequency	CL = 15pF	400	MHz
f _{max}	Input Frequency	CL = 5pF	900	MHz
f _{max}	Input Frequency	CL = 2pF	1240	MHz

Notes:

1. See test circuits and waveforms.
2. t_{pLH}, t_{pHL}, t_{sk(p)}, and t_{sk(o)} are production tested. All other parameters guaranteed but not production tested.
3. Airflow of 1m/s is recommended for frequencies above 133MHz

Test Circuit

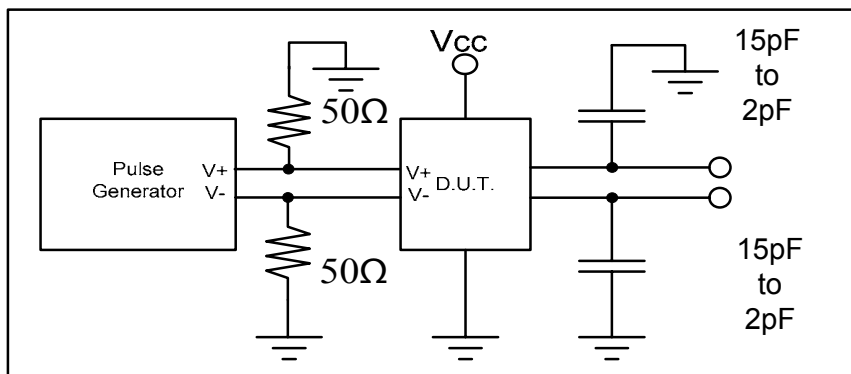

2.4V -3.6V Differential inputs to HSTL outputs Clock Buffer

Test Waveforms

FIGURE 1. LVDS/ PECL/ ECL/ HSTL /DIFFERENTIAL INPUT WAVEFORM DEFINITIONS

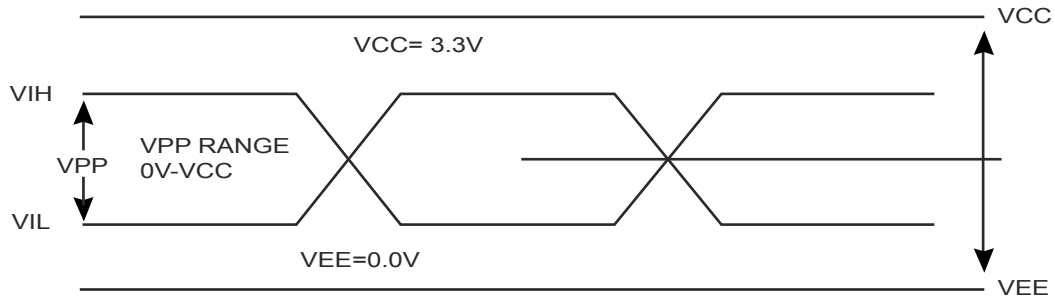

FIGURE 2. HSTL/HSTL OUTPUT

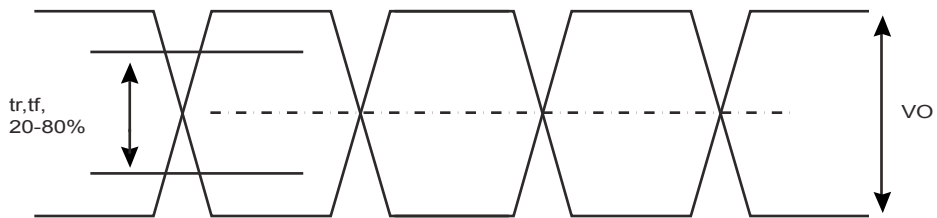
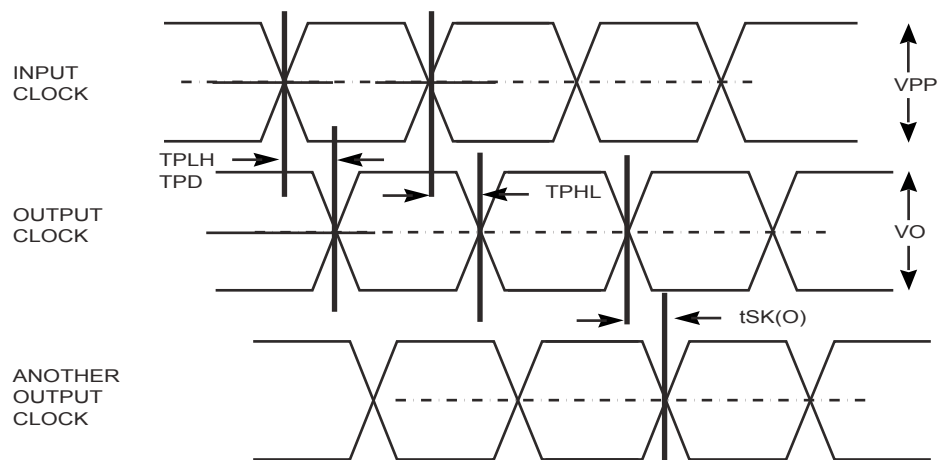
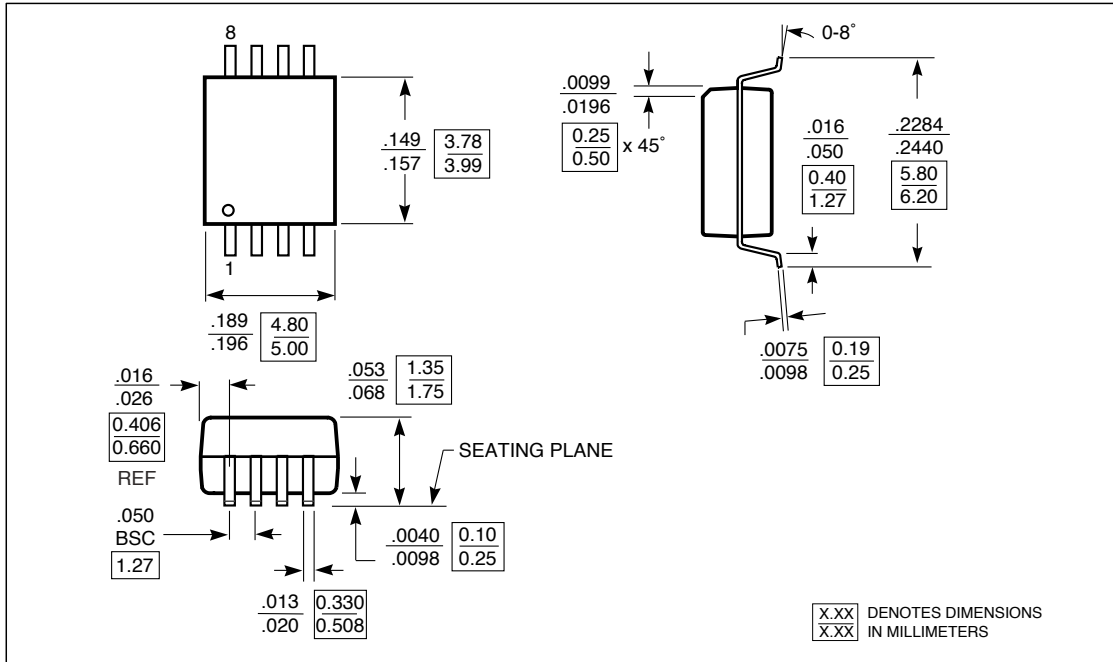

FIGURE 3. Propagation Delay, Output pulse skew, and output-to-output skew for D to output pair



2.4V -3.6V Differential inputs to HSTL outputs Clock Buffer

Packaging Mechanical Drawing: 8 pin SOIC



Packaging Mechanical Drawing: 8 pin TSSOP

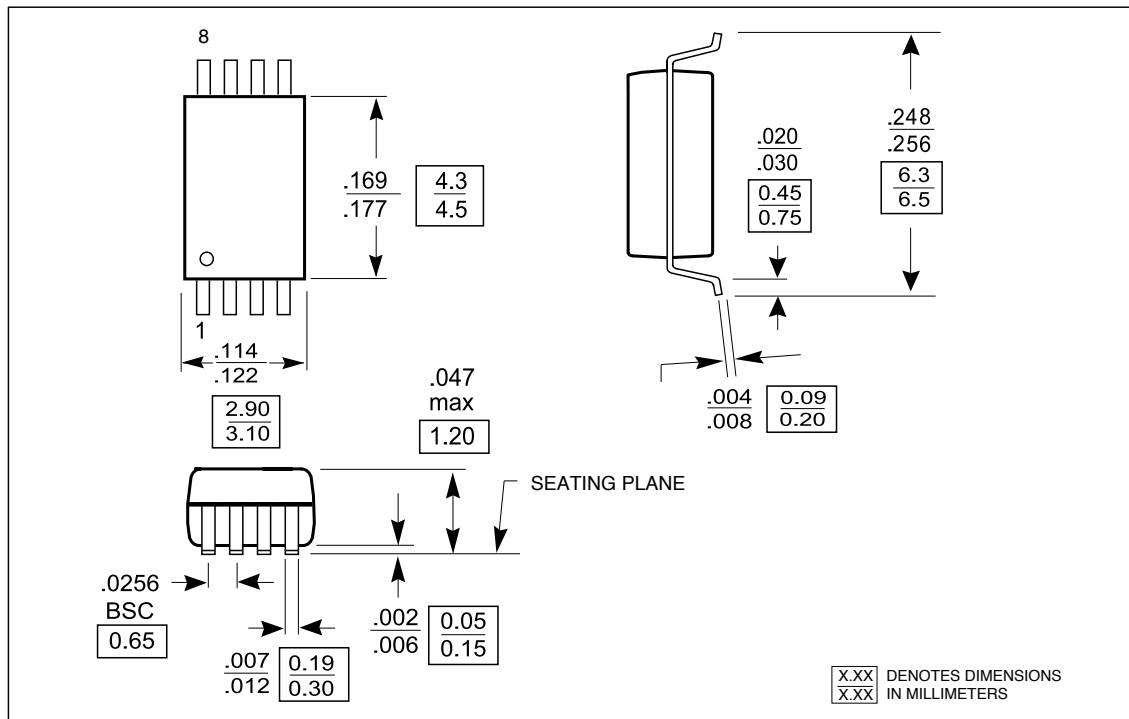

2.4V -3.6V Differential inputs to HSTL outputs Clock Buffer

Ordering Information

Ordering Code	Package			Top-Marking	T _A
PO100HSTL11ASU	8pin SOIC	Tube	Pb-free & Green	PO100HSTL11AS	-40°C to 85°C
PO100HSTL11ASR	8pin SOIC	Tape and reel	Pb-free & Green	PO100HSTL11AS	-40°C to 85°C
PO100HSTL11ATU	8pin TSSOP	Tube	Pb-free & Green	PO100HSTL11AT	-40°C to 85°C
PO100HSTL11ATR	8pin TSSOP	Tape and reel	Pb-free & Green	PO100HSTL11AT	-40°C to 85°C