

DESCRIPTION

The System Sensor 2400 Series photoelectronic smoke detectors are specifically designed to meet the performance requirements of fire detection/alarm systems. These detectors use state-of-the-art optical sensing chambers. The detectors are designed to provide open area detection and are compatible with FCI fire alarm control panels. The detectors' operation and sensitivity can be tested in place. The Model 2400T unit has the same specifications as the Model 2400, but in addition it features a built-in fixed temperature (135° F) thermal detection unit.

Each detector has an LED which flashes every ten seconds indicating that power is being applied to the detector. The LED lights steadily when the detector is in alarm. A remote LED annunciator is available as an optional accessory.

The 2400 and 2400T detectors include a tamper-resistant feature that, when used, prevents removal of the detector without the use of a tool.

Sensitivity testing is performed either by inserting a tool into the recessed test switch opening or inserting a calibrated test card according to the test procedures.

Field metering of detector sensitivity may be performed with the aid of a voltmeter and test kit MOD 400R.



FEATURES

- Built-in Tamper-resistant Feature**
- Built-in Test Switch**
- Built-in Visual Alarm Indicator**
- Remote LED Option**
- Compatible with FCI Control Panels**
- Field Metering of Detector Sensitivity**
- Removable Insect Screen and Cover for Field Cleaning**
- Sealed against Dirt, Insects, and Back Pressure**
- Insect-resistant Screening (.020"/.508mm openings)**
- Convenient Terminal Strip Wiring**

APPROVALS



TECHNICAL SPECIFICATIONS

Nominal sensitivity	3.0%/ft. obscuration
Operating voltage	8.5 - 35 VDC (24 VDC nominal)
Operating current	120 uA maximum
Operating temperature	32° to 120° F (0° to 49° C)
Operating humidity	10% to 93% relative humidity
Air velocity	3,000 fpm max.
Construction	Off-white flame-retardant plastic
Diameter	5.5 inches (14 cm)
Height	3.19 inches (8.0 cm) high,
Weight	0.7 lb. (310 gm)

NOTE: Alarm current is limited by control panel initiating device circuit.

ORDERING INFORMATION

Part Number	Model	Description
	2400	Photoelectronic Detector
	2400T	Photoelectronic Detector w/135° F thermal

MOUNTING

On a 4-inch square box with plaster ring and FCI supplied mounting bracket kit. Minimum depth 1.5 inches.

On a 3.5 or 4-inch octagonal box. Minimum depth 1.5 inches.

Directly to ceiling using plastic screw anchors.

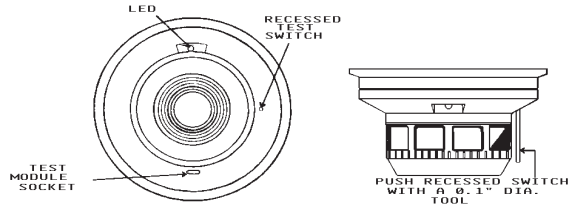

VIEWS SHOWING POSITION OF TEST MAGNET

INSTALLATION

Line up the arrows on the detector with the arrows on the mounting bracket. Turn the detector clockwise until the detector clicks into place.

To use the tamper-proof feature, break the smaller tab at the scribed line in the tamper-proof tab located on the detector mounting bracket. Install the detector. To remove the detector from the bracket when using the tamper-proof feature, insert the blade of a small screwdriver into the hole on the side of the base and push the plastic lever away from the detector head. Turn the detector counterclockwise for removal. NOTE: The decorative ring must be removed in order to remove a head after it has been made tamper-proof.

NOTE: The number of two-wire smoke detectors which can be accommodated per zone varies with different control panels. Consult the control panel instruction manual to determine the capacity.

Refer to NFPA 72, Chapter 5-3 "Smoke Sensing Fire Detectors", for spacing, location of detectors and other guidelines.

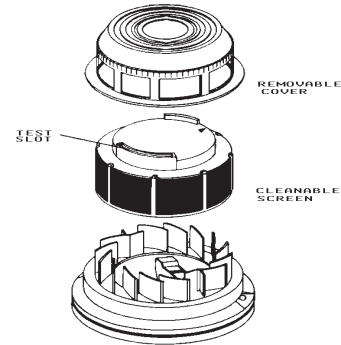

WARNING: To prevent detector contamination during construction, smoke detectors must be protected from dust and contamination until area is clean and dust free. See NFPA 72-5-3.7.1.3

TESTING

Detectors may be tested locally in the following ways:

A. Insert a tool into the test opening in the unit. For the complete procedure, refer to the Installation and Maintenance Instructions furnished with each detector.

B. A test card with one end marked "ALARM" and the other end marked "NO ALARM" is furnished with each unit. For the complete procedure, refer to the Installation and Maintenance Instructions furnished with each detector.

C. Field metering of detector sensitivity may be performed with the aid of a voltmeter and test kit MOD 400R. For the complete procedure, refer to the Installation and Maintenance Instructions furnished with each detector.

MAINTENANCE

Cleaning programs should be adapted to the individual environment, in conformance with NFPA Standard 72. We recommend, at the least, an annual cleaning of the unit. The detector screen and cover assembly can be removed, revealing the sensing chamber. A vacuum cleaner can be used to remove dust from the screen, cover and sensing chamber. For the complete procedure, refer to the Installation and Maintenance Instructions furnished with each detector.

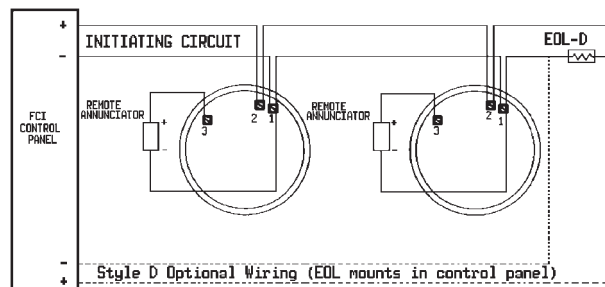

WIRING DIAGRAM FOR USE WITH FCI CONTROL PANELS