

# AMIS-42675

## High Speed Low Power CAN Transceiver for Long Wire Networks

### Description

The AMIS-42675 CAN transceiver is the interface between a controller area network (CAN) protocol controller and the physical bus. It may be used in both 12 V and 24 V systems. The transceiver provides differential transmit capability to the bus and differential receive capability to the CAN controller.

Due to the wide common-mode voltage range of the receiver inputs, the AMIS-42675 is able to reach outstanding levels of electro-magnetic susceptibility (EMS). Similarly, extremely low electromagnetic emission (EME) is achieved by the excellent matching of the output signals.

The AMIS-42675 is the industrial version of the AMIS-42665 and primarily for applications where long network lengths are mandatory. Examples are elevators, in-building networks, process control and trains. To cope with the long bus delay the communication speed needs to be low. AMIS-42675 allows low transmit data rates down 10 Kbit/s or lower.

The AMIS-42675 is the low power member of the CAN high-speed transceiver family and offers the following additional features:

### Features

- Ideal Passive Behavior When Supply Voltage is Removed
- Wake-up Over Bus
- Extremely Low Current Standby Mode
- Compatible With the ISO 11898 standard (ISO 11898-2, ISO 11898-5 and SAE J2284)
- Wide Range of Bus Communication Speed (0 up to 1 Mbit/s)
- Ideally Suited for 12 V and 24 V Industrial and Automotive Applications
- Allows Low Transmit Data Rate in Networks Exceeding 1 km
- Extremely Low Current Standby Mode with Wake-up via the Bus
- Low Electromagnetic Emission (EME):  
Common-Mode Choke is No Longer Required
- Differential Receiver with Wide Common-Mode Range ( $\pm 35$  V) for High EMS



ON Semiconductor®

<http://onsemi.com>

### PIN ASSIGNMENT

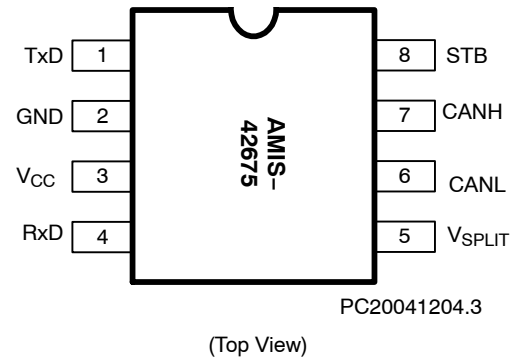

### ORDERING INFORMATION

See detailed ordering and shipping information in the package dimensions section on page 11 of this data sheet.

- Voltage Source via  $V_{SPLIT}$  Pin for Stabilizing the Recessive Bus Level (Further EMC Improvement)
- No Disturbance of the Bus Lines with an Unpowered Node
- Thermal Protection
- Bus Pins Protected Against Transients
- Power Down Mode in Which the Transmitter is Disabled
- Bus and  $V_{SPLIT}$  Pins Short Circuit Proof to Supply Voltage and Ground
- Logic Level Inputs Compatible with 3.3 V Devices
- At Least 110 Nodes can be Connected to the Same Bus
- These are Pb-Free Devices\*

\*For additional information on our Pb-Free strategy and soldering details, please download the ON Semiconductor Soldering and Mounting Techniques Reference Manual, SOLDERRM/D.

Table 1. TECHNICAL CHARACTERISTICS

Symbol	Parameter	Condition	Max	Max	Unit
V <sub>CC</sub>	Power Supply Voltage		4.75	5.25	V
V <sub>STB</sub>	DC Voltage at Pin STB		-0.3	V <sub>CC</sub>	V
V <sub>TxD</sub>	DC Voltage at Pin TxD		-0.3	V <sub>CC</sub>	V
V <sub>RxD</sub>	DC Voltage at Pin RxD		-0.3	V <sub>CC</sub>	V
V <sub>CANH</sub>	DC Voltage at Pin CANH	0 < V <sub>CC</sub> < 5.25 V; No Time Limit	-35	+35	V
V <sub>CANL</sub>	DC Voltage at Pin CANL	0 < V <sub>CC</sub> < 5.25 V; No Time Limit	-35	+35	V
V <sub>SPLIT</sub>	DC Voltage at Pin V <sub>SPLIT</sub>	0 < V <sub>CC</sub> < 5.25 V; No Time Limit	-35	+35	V
V <sub>O(dif)(bus_dom)</sub>	Differential Bus Output Voltage in Dominant State	42.5 Ω < R <sub>LT</sub> < 60 Ω	1.5	3	V
CM-range	Input Common-Mode Range for Comparator	Guaranteed Differential Receiver Threshold and Leakage Current	-35	+35	V
V <sub>CM-peak</sub>	Common-Mode Peak	Note 1	-500	500	mV
C <sub>load</sub>	Load Capacitance on IC Outputs			15	pF
t <sub>pd(rec-dom)</sub>	Propagation Delay TxD to RxD	See Figure 4	70	230	ns
t <sub>pd(dom-rec)</sub>	Propagation Delay TxD to RxD	See Figure 4	100	245	ns
V <sub>CM-step</sub>	Common-Mode Step	Note 1	-150	150	mV
T <sub>junc</sub>	Junction Temperature		-40	150	°C

1. The parameters V<sub>CM-peak</sub> and V<sub>CM-step</sub> guarantee low EME.

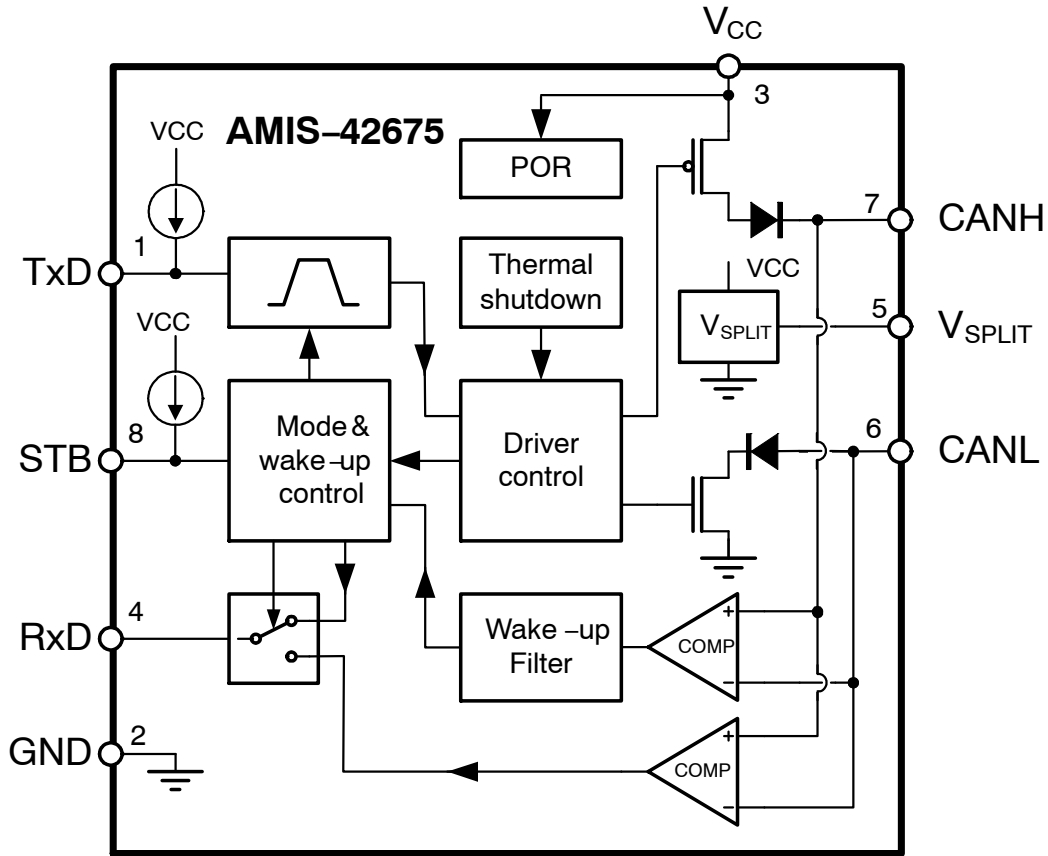

PC20071005.2

Figure 1. Block Diagram

**Table 2. PIN DESCRIPTION**

Pin	Name	Description
1	TxD	Transmit Data Input; Low Input → Dominant Driver; Internal Pullup Current
2	GND	Ground
3	V <sub>CC</sub>	Supply Voltage
4	RxD	Receive Data Output; Dominant Transmitter → Low Output
5	V <sub>SPLIT</sub>	Common-Mode Stabilization Output
6	CANL	Low-Level CAN Bus Line (Low in Dominant Mode)
7	CANH	High-Level CAN Bus Line (High in Dominant Mode)
8	STB	Standby Mode Control Input

**Table 3. ABSOLUTE MAXIMUM RATINGS**

Symbol	Parameter	Conditions	Min	Max	Unit
V <sub>CC</sub>	Supply Voltage		-0.3	+7	V
V <sub>CANH</sub>	DC Voltage at Pin CANH	0 < V <sub>CC</sub> < 5.25 V; No Time Limit	-50	+50	V
V <sub>CANL</sub>	DC Voltage at Pin CANL	0 < V <sub>CC</sub> < 5.25 V; No Time Limit	-50	+50	V
V <sub>SPLIT</sub>	DC Voltage at Pin V <sub>SPLIT</sub>	0 < V <sub>CC</sub> < 5.25 V; No Time Limit	-50	+50	V
V <sub>TxD</sub>	DC Voltage at Pin TxD		-0.3	V <sub>CC</sub> + 0.3	V
V <sub>RxD</sub>	DC Voltage at Pin RxD		-0.3	V <sub>CC</sub> + 0.3	V
V <sub>STB</sub>	DC Voltage at Pin STB		-0.3	V <sub>CC</sub> + 0.3	V
V <sub>tran(CANH)</sub>	Transient Voltage at Pin CANH	Note 2	-300	+300	V
V <sub>tran(CANL)</sub>	Transient Voltage at Pin CANL	Note 2	-300	+300	V
V <sub>tran(VSPLIT)</sub>	Transient Voltage at Pin V <sub>SPLIT</sub>	Note 2	-300	+300	V
V <sub>esd</sub> (	Electrostatic Discharge Voltage at all Pins	Note 4 Note 5	-5 -750	+5 +750	kV V
Latch-up	Static Latch-up at All Pins	Note 4		120	mA
T <sub>stg</sub>	Storage Temperature		-55	+150	°C
T <sub>A</sub>	Ambient Temperature		-40	+125	°C
T <sub>J</sub>	Maximum Junction Temperature		-40	+170	°C

Stresses exceeding Maximum Ratings may damage the device. Maximum Ratings are stress ratings only. Functional operation above the Recommended Operating Conditions is not implied. Extended exposure to stresses above the Recommended Operating Conditions may affect device reliability.

- Applied transient waveforms in accordance with ISO 7637 part 3, test pulses 1, 2, 3a, and 3b (see Figure 3).
- Standardized human body model electrostatic discharge (ESD) pulses in accordance to MIL883 method 3015.7.
- Static latch-up immunity: Static latch-up protection level when tested according to EIA/JESD78.
- Standardized charged device model ESD pulses when tested according to EOS/ESD DS5.3-1993.

**Table 4. THERMAL CHARACTERISTICS**

Symbol	Parameter	Conditions	Value	Unit
R <sub>th(vj-a)</sub>	Thermal Resistance from Junction-to-Ambient in SOIC-8 Package	In Free Air	145	k/W
R <sub>th(vj-s)</sub>	Thermal Resistance from Junction-to-Substrate of Bare Die	In Free Air	45	k/W

# AMIS-42675

## APPLICATION SCHEMATIC

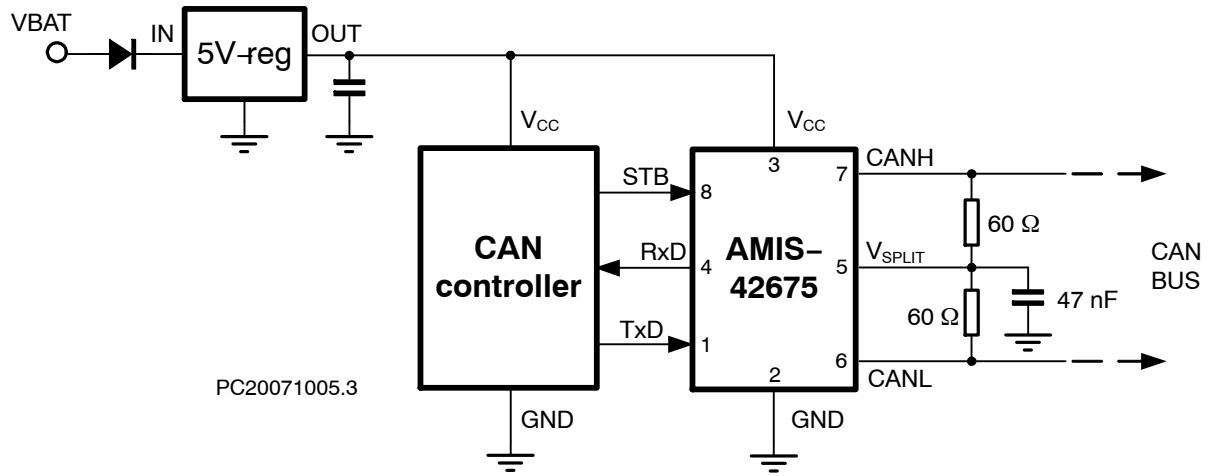

Figure 2. Application Diagram

FUNCTIONAL DESCRIPTION

**Operating Modes**

AMIS-42675 provides two modes of operation as illustrated in Table 5. These modes are selectable through Pin STB.

**Table 5. OPERATING MODES**

Mode	Pin STB	Pin RXD	
		Low	High
Normal	Low	Bus Dominant	Bus Recessive
Standby	High	Wake-up Request Detected	No wake-up Request Detected

**Normal Mode**

In the normal mode, the transceiver is able to communicate via the bus lines. The signals are transmitted and received to the CAN controller via the Pins TxD and RxD. The slopes on the bus lines outputs are optimized to give extremely low EME.

**Standby Mode**

In stand-by mode both the transmitter and receiver are disabled and a very low-power differential receiver monitors the bus lines for CAN bus activity. The bus lines are terminated to ground and supply current is reduced to a minimum, typically 10  $\mu$ A. When a wake-up request is detected by the low-power differential receiver, the signal is first filtered and then verified as a valid wake signal after a time period of  $t_{BUS}$ , the RxD Pin is driven low by the transceiver to inform the controller of the wake-up request.

**Split Circuit**

The  $V_{SPLIT}$  Pin is operational only in normal mode. In standby mode this pin is floating. The  $V_{SPLIT}$  is connected as shown in Figure 2 and its purpose is to provide a stabilized DC voltage of  $0.5 \times V_{CC}$  to the bus avoiding possible steps in the common-mode signal therefore reducing EME. These unwanted steps could be caused by an un-powered node on the network with excessive leakage current from the bus that shifts the recessive voltage from its nominal  $0.5 \times V_{CC}$  voltage.

**Wake-up**

Once a valid wake-up (dominant state longer than  $t_{BUS}$ ) has been received during the standby mode, the RxD Pin is driven low.

**Overtemperature Detection**

A thermal protection circuit protects the IC from damage by switching off the transmitter if the junction temperature exceeds a value of approximately 160°C. Because the transmitter dissipates most of the power, the power dissipation and temperature of the IC is reduced. All other IC functions continue to operate. The transmitter off-state resets when Pin TxD goes high. The thermal protection circuit is particularly needed when a bus line short circuits.

**High Communication Speed Range**

The transceiver is primarily intended for industrial applications. It allows very low baud rates needed for long bus length applications. But also high speed communication is possible up to 1 Mbit/s.

**Fail Safe Features**

A current-limiting circuit protects the transmitter output stage from damage caused by accidental short circuit to either positive or negative supply voltage, although power dissipation increases during this fault condition.

The Pins CANH and CANL are protected from automotive electrical transients (according to ISO 7637; see Figure 3). Pins TxD and STB are pulled high internally should the input become disconnected. Pins TxD, STB and RxD will be floating, preventing reverse supply should the  $V_{CC}$  supply be removed.

ELECTRICAL CHARACTERISTICS

Definitions

All voltages are referenced to GND (pin 2). Positive currents flow into the IC. Sinking current means the current is flowing into the pin; sourcing current means the current is flowing out of the pin.

**Table 6. DC CHARACTERISTICS**  $V_{CC} = 4.75\text{ V to }5.25\text{ V}$ ,  $T_J = -40^\circ\text{C to }+150^\circ\text{C}$ ;  $R_{LT} = 60\ \Omega$  unless specified otherwise.

Symbol	Parameter	Conditions	Min	Typ	Max	Unit
<b>SUPPLY (Pin V<sub>CC</sub>)</b>						
I <sub>CC</sub>	Supply Current	Dominant; V <sub>TxD</sub> = 0 V Recessive; V <sub>TxD</sub> = V <sub>CC</sub>		45 4	65 8	mA
I <sub>CCS</sub>	Supply Current in Standby Mode	T <sub>junc,max</sub> = 100°C		10	15	μA
<b>TRANSMITTER DATA INPUT (Pin TxD)</b>						
V <sub>IH</sub>	High-Level Input Voltage	Output recessive	2.0	–	V <sub>CC</sub> + 0.3	V
V <sub>IL</sub>	Low-Level Input Voltage	Output Dominant	–0.3	–	+0.8	V
I <sub>IH</sub>	High-Level Input Current	V <sub>TxD</sub> = V <sub>CC</sub>	–5	0	+5	μA
I <sub>IL</sub>	Low-Level Input Current	V <sub>TxD</sub> = 0 V	–75	–200	–350	μA
C <sub>i</sub>	Input Capacitance	Not Tested	–	5	10	pF
<b>TRANSMITTER MODE SELECT (Pin STB)</b>						
V <sub>IH</sub>	High-Level Input Voltage	Standby Mode	2.0	–	V <sub>CC</sub> + 0.3	V
V <sub>IL</sub>	Low-Level Input Voltage	Normal Mode	–0.3	–	+0.8	V
I <sub>IH</sub>	High-Level Input Current	V <sub>STB</sub> = V <sub>CC</sub>	–5	0	+5	μA
I <sub>IL</sub>	Low-Level Input Current	V <sub>STB</sub> = 0 V	–1	–4	–10	μA
C <sub>i</sub>	Input Capacitance	Not Tested	–	5	10	pF
<b>RECEIVER DATA OUTPUT (Pin RxD)</b>						
V <sub>OH</sub>	High-level output voltage	I <sub>RxD</sub> = –10 mA	0.6 x V <sub>CC</sub>		0.75 x V <sub>CC</sub>	V
V <sub>OL</sub>	Low-level output voltage	I <sub>RxD</sub> = 5 mA		0.25	0.45	V
I <sub>oh</sub>	High-level output current	V <sub>o</sub> = 0.7 x V <sub>CC</sub>	–5	–10	–15	mA
I <sub>ol</sub>	Low-level output current	V <sub>o</sub> = 0.3 x V <sub>CC</sub>	5	10	15	mA
<b>BUS LINES (Pins CANH and CANL)</b>						
V <sub>o(reces)(norm)</sub>	Recessive Bus Voltage	V <sub>TxD</sub> = V <sub>CC</sub> ; No Load Normal Mode	2.0	2.5	3.0	V
V <sub>o(reces)(stby)</sub>	Recessive Bus Voltage	V <sub>TxD</sub> = V <sub>CC</sub> ; No Load Standby Mode	–100	0	100	mV
I <sub>o(reces)(CANH)</sub>	Recessive Output Current at Pin CANH	–35 V < V <sub>CANH</sub> < +35 V; 0 V < V <sub>CC</sub> < 5.25 V	–2.5	–	+2.5	mA
I <sub>o(reces)(CANL)</sub>	Recessive Output Current at Pin CANL	–35 V < V <sub>CANL</sub> < +35 V; 0 V < V <sub>CC</sub> < 5.25 V	–2.5	–	+2.5	mA
V <sub>o(dom)(CANH)</sub>	Dominant Output Voltage at Pin CANH	V <sub>TxD</sub> = 0 V	3.0	3.6	4.25	V
V <sub>o(dom)(CANL)</sub>	Dominant Output Voltage at Pin CANL	V <sub>TxD</sub> = 0 V	0.5	1.4	1.75	V
V <sub>o(dif)(bus_dom)</sub>	Differential Bus Output Voltage (V <sub>CANH</sub> – V <sub>CANL</sub> )	V <sub>TxD</sub> = 0 V; Dominant; 42.5 Ω < R <sub>LT</sub> < 60 Ω	1.5	2.25	3.0	V
V <sub>o(dif)(bus_rec)</sub>	Differential Bus Output Voltage (V <sub>CANH</sub> – V <sub>CANL</sub> )	V <sub>TxD</sub> = V <sub>CC</sub> ; Recessive; No Load	–120	0	+50	mV
I <sub>o(sc)(CANH)</sub>	Short Circuit Output Current at Pin CANH	V <sub>CANH</sub> = 0 V; V <sub>TxD</sub> = 0 V	–45	–70	–120	mA

# AMIS-42675

**Table 6. DC CHARACTERISTICS**  $V_{CC} = 4.75\text{ V to }5.25\text{ V}$ ,  $T_J = -40^\circ\text{C to }+150^\circ\text{C}$ ;  $R_{LT} = 60\ \Omega$  unless specified otherwise.

Symbol	Parameter	Conditions	Min	Typ	Max	Unit
<b>BUS LINES (Pins CANH and CANL)</b>						
$I_{o(sc)}(CANL)$	Short Circuit Output Current at Pin CANL	$V_{CANL} = 36\text{ V}$ ; $V_{TXD} = 0\text{ V}$	45	70	120	mA
$V_{i(dif)}(th)$	Differential Receiver Threshold Voltage (see Figure 4)	$-5\text{ V} < V_{CANL} < +12\text{ V}$ ; $-5\text{ V} < V_{CANH} < +12\text{ V}$ ;	0.5	0.7	0.9	V
$V_{ihcm(dif)}(th)$	Differential Receiver Threshold Voltage for High Common-Mode (see Figure 4)	$35\text{ V} < V_{CANL} < +35\text{ V}$ ; $-35\text{ V} < V_{CANH} < +35\text{ V}$ ;	0.40	0.7	1.00	V
$V_{i(dif)}(hys)$	Differential Receiver Input Voltage Hysteresis (see Figure 4)	$-35\text{ V} < V_{CANL} < +35\text{ V}$ ; $-35\text{ V} < V_{CANH} < +35\text{ V}$ ;	50	70	100	mV
$R_{i(cm)}(CANH)$	Common-Mode Input Resistance at Pin CANH		15	26	37	k $\Omega$
$R_{i(cm)}(CANL)$	Common-Mode Input Resistance at Pin CANL		15	26	37	k $\Omega$
$R_{i(cm)}(m)$	Matching Between Pin CANH and Pin CANL Common Mode Input Resistance	$V_{CANH} = V_{CANL}$	-3	0	+3	%
$R_{i(dif)}$	Differential Input Resistance		25	50	75	k $\Omega$
$C_{i}(CANH)$	Input Capacitance at Pin CANH	$V_{TXD} = V_{CC}$ ; Not Tested		7.5	20	pF
$C_{i}(CANL)$	Input Capacitance at Pin CANL	$V_{TXD} = V_{CC}$ ; Not Tested		7.5	20	pF
$C_{i}(dif)$	Differential Input Capacitance	$V_{TXD} = V_{CC}$ ; Not Tested		3.75	10	pF
<b>COMMON-MODE STABILIZATION (Pin <math>V_{SPLIT}</math>)</b>						
$V_{SPLIT}$	Reference Output Voltage at Pin $V_{SPLIT}$	Normal Mode; $-500\ \mu\text{A} < I_{SPLIT} < 500\ \mu\text{A}$	$0.3 \times V_{CC}$	-	$0.7 \times V_{CC}$	
$I_{SPLIT}(l)$	$V_{SPLIT}$ Leakage Current	Standby Mode	-5		+5	$\mu\text{A}$
$I_{SPLIT}(lim)$	$V_{SPLIT}$ Limitation Current	Normal Mode	-3		+3	mA
<b>POWER-ON-RESET (POR)</b>						
PORL	POR Level	CANH, CANL, $V_{ref}$ in Tri-State Below POR Level	2.2	3.5	4.7	V
<b>THERMAL SHUTDOWN</b>						
$T_{J(sd)}$	Shutdown Junction Temperature		150	160	180	$^\circ\text{C}$
<b>TIMING CHARACTERISTICS (see Figures 3 and 4)</b>						
$t_d(TXD-BUSon)$	Delay TXD to Bus Active	$C_l = 100\text{ pF}$ between CANH to CANL	40	85	105	ns
$t_d(TXD-BUSoff)$	Delay TXD to Bus Inactive	$C_l = 100\text{ pF}$ between CANH to CANL	30	60	105	ns
$t_d(BUSon-RXD)$	Delay Bus Active to RXD	$C_{rxd} = 15\text{ pF}$	25	55	105	ns
$t_d(BUSoff-RXD)$	Delay Bus Inactive to RXD	$C_{rxd} = 15\text{ pF}$	40	100	105	ns
$t_{pd}(rec-dom)$	Propagation Delay TXD to RXD from Recessive to Dominant	$C_l = 100\text{ pF}$ between CANH to CANL	90		230	ns
$t_{d}(dom-rec)$	Propagation delay TXD to RXD from Dominant to Recessive	$C_l = 100\text{ pF}$ between CANH to CANL	90		245	ns
$t_d(stb-nm)$	Delay Standby Mode to Normal Mode		5	7.5	10	$\mu\text{s}$
$t_{dbus}$	Dominant Time for Wake-up via Bus		0.75	2.5	5	$\mu\text{s}$

# AMIS-42675

## MEASUREMENT SETUPS AND DEFINITIONS

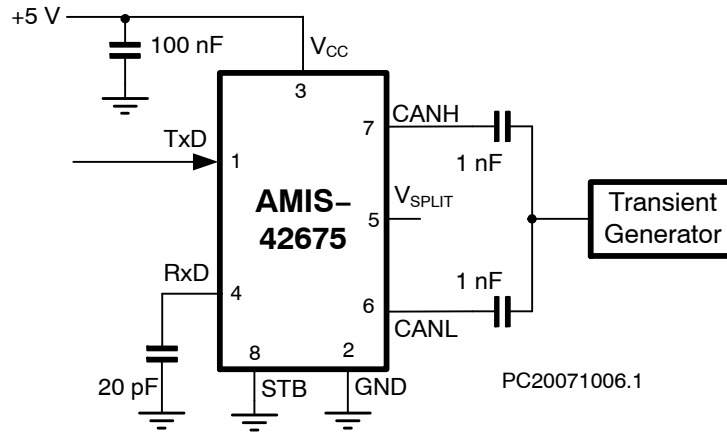

Figure 3. Test Circuit for Transients

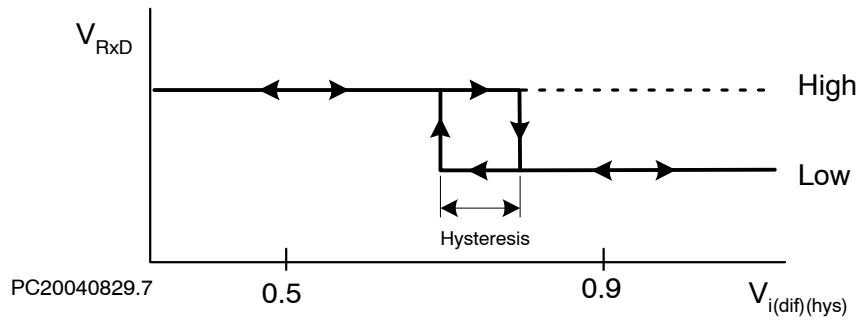

Figure 4. Hysteresis of the Receiver

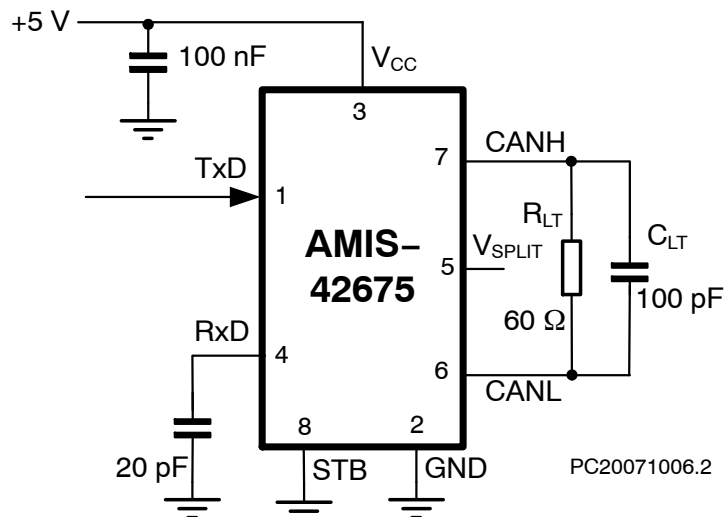

Figure 5. Test Circuit for Timing Characteristics



# AMIS-42675

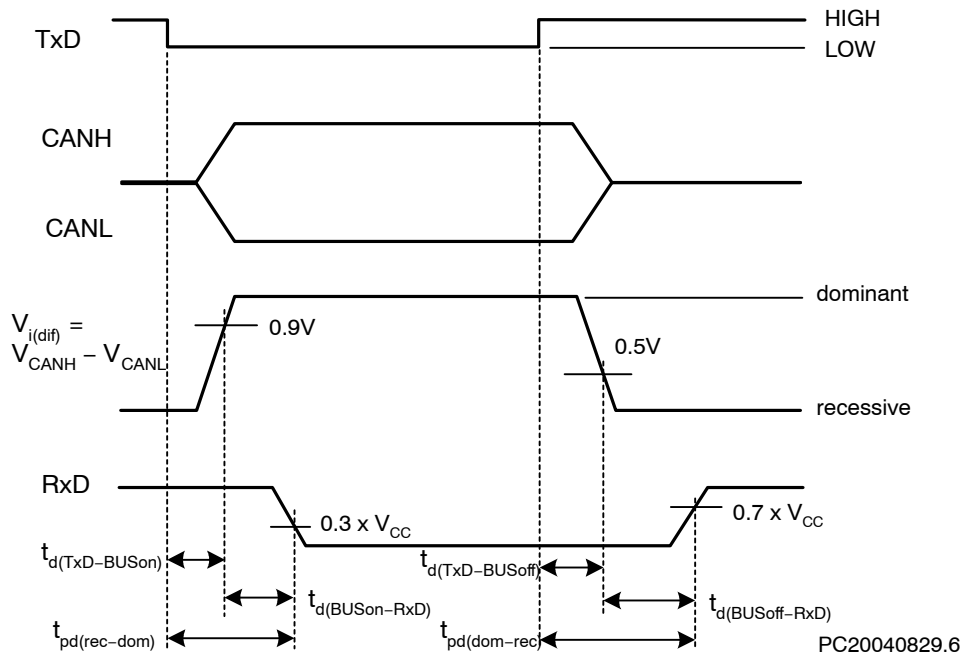

Figure 6. Timing Diagram for AC Characteristics

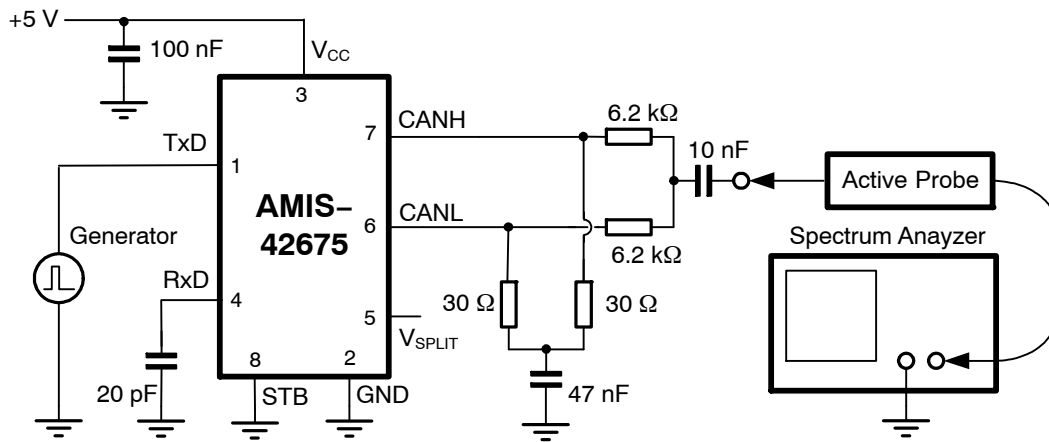

Figure 7. Basic Test Set-up for EME

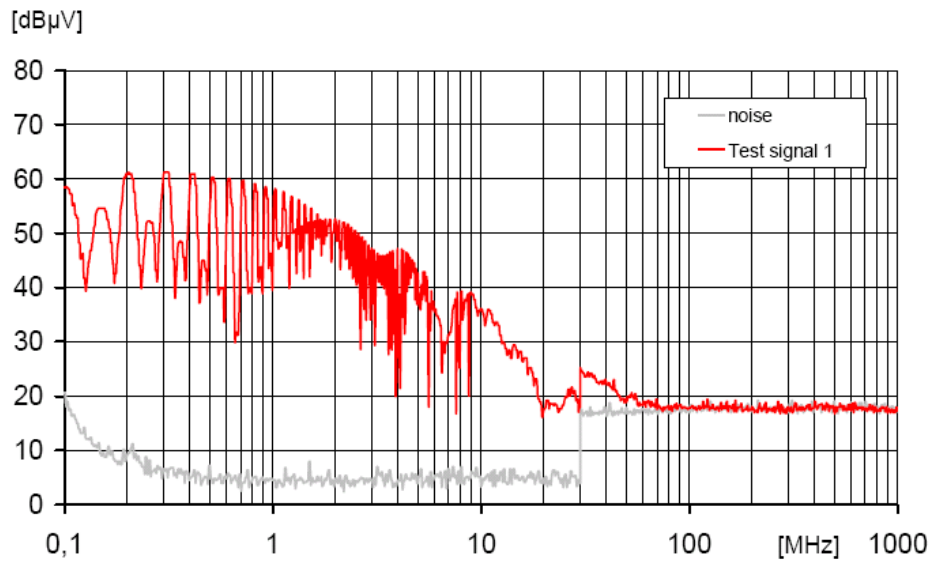

Figure 8. EME Measurements

# AMIS-42675

## DEVICE ORDERING INFORMATION

Part Number	Temperature Range	Package Type	Shipping <sup>†</sup>
AMIS42675ICAH2G	-40°C - 125°C	SOIC-8 (Pb-Free)	96 Tube / Tray
AMIS42675ICAH2RG	-40°C - 125°C	SOIC-8 (Pb-Free)	3000 / Tape & Reel

<sup>†</sup>For information on tape and reel specifications, including part orientation and tape sizes, please refer to our Tape and Reel Packaging Specifications Brochure, BRD8011/D.

# AMIS-42675

## PACKAGE DIMENSIONS

SOIC 8  
CASE 751AZ-01  
ISSUE O

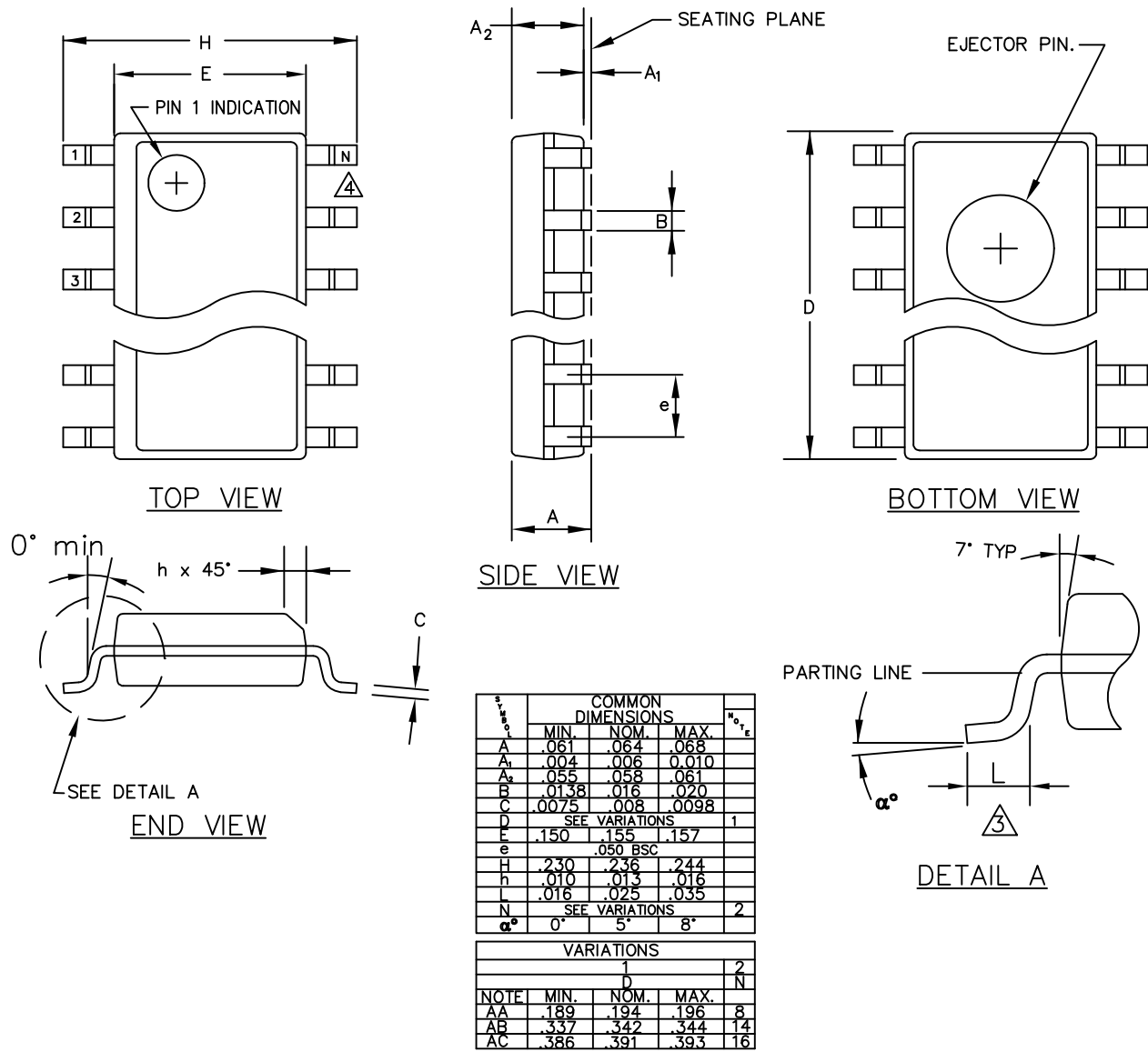

1. ALL DIMENSIONS ARE IN MILLIMETERS.

**ON Semiconductor** and **ON** are registered trademarks of Semiconductor Components Industries, LLC (SCILLC). SCILLC reserves the right to make changes without further notice to any products herein. SCILLC makes no warranty, representation or guarantee regarding the suitability of its products for any particular purpose, nor does SCILLC assume any liability arising out of the application or use of any product or circuit, and specifically disclaims any and all liability, including without limitation special, consequential or incidental damages. "Typical" parameters which may be provided in SCILLC data sheets and/or specifications can and do vary in different applications and actual performance may vary over time. All operating parameters, including "Typicals" must be validated for each customer application by customer's technical experts. SCILLC does not convey any license under its patent rights nor the rights of others. SCILLC products are not designed, intended, or authorized for use as components in systems intended for surgical implant into the body, or other applications intended to support or sustain life, or for any other application in which the failure of the SCILLC product could create a situation where personal injury or death may occur. Should Buyer purchase or use SCILLC products for any such unintended or unauthorized application, Buyer shall indemnify and hold SCILLC and its officers, employees, subsidiaries, affiliates, and distributors harmless against all claims, costs, damages, and expenses, and reasonable attorney fees arising out of, directly or indirectly, any claim of personal injury or death associated with such unintended or unauthorized use, even if such claim alleges that SCILLC was negligent regarding the design or manufacture of the part. SCILLC is an Equal Opportunity/Affirmative Action Employer. This literature is subject to all applicable copyright laws and is not for resale in any manner.

### PUBLICATION ORDERING INFORMATION

**LITERATURE FULFILLMENT:**  
Literature Distribution Center for ON Semiconductor  
P.O. Box 5163, Denver, Colorado 80217 USA  
**Phone:** 303-675-2175 or 800-344-3860 Toll Free USA/Canada  
**Fax:** 303-675-2176 or 800-344-3867 Toll Free USA/Canada  
**Email:** orderlit@onsemi.com

**N. American Technical Support:** 800-282-9855 Toll Free  
USA/Canada  
**Europe, Middle East and Africa Technical Support:**  
Phone: 421 33 790 2910  
**Japan Customer Focus Center**  
Phone: 81-3-5773-3850

**ON Semiconductor Website:** [www.onsemi.com](http://www.onsemi.com)  
**Order Literature:** <http://www.onsemi.com/orderlit>  
For additional information, please contact your local Sales Representative